

25FD3672 AND 25MFD3672 MANUAL / MOTORIZED FRESH AIR DAMPER

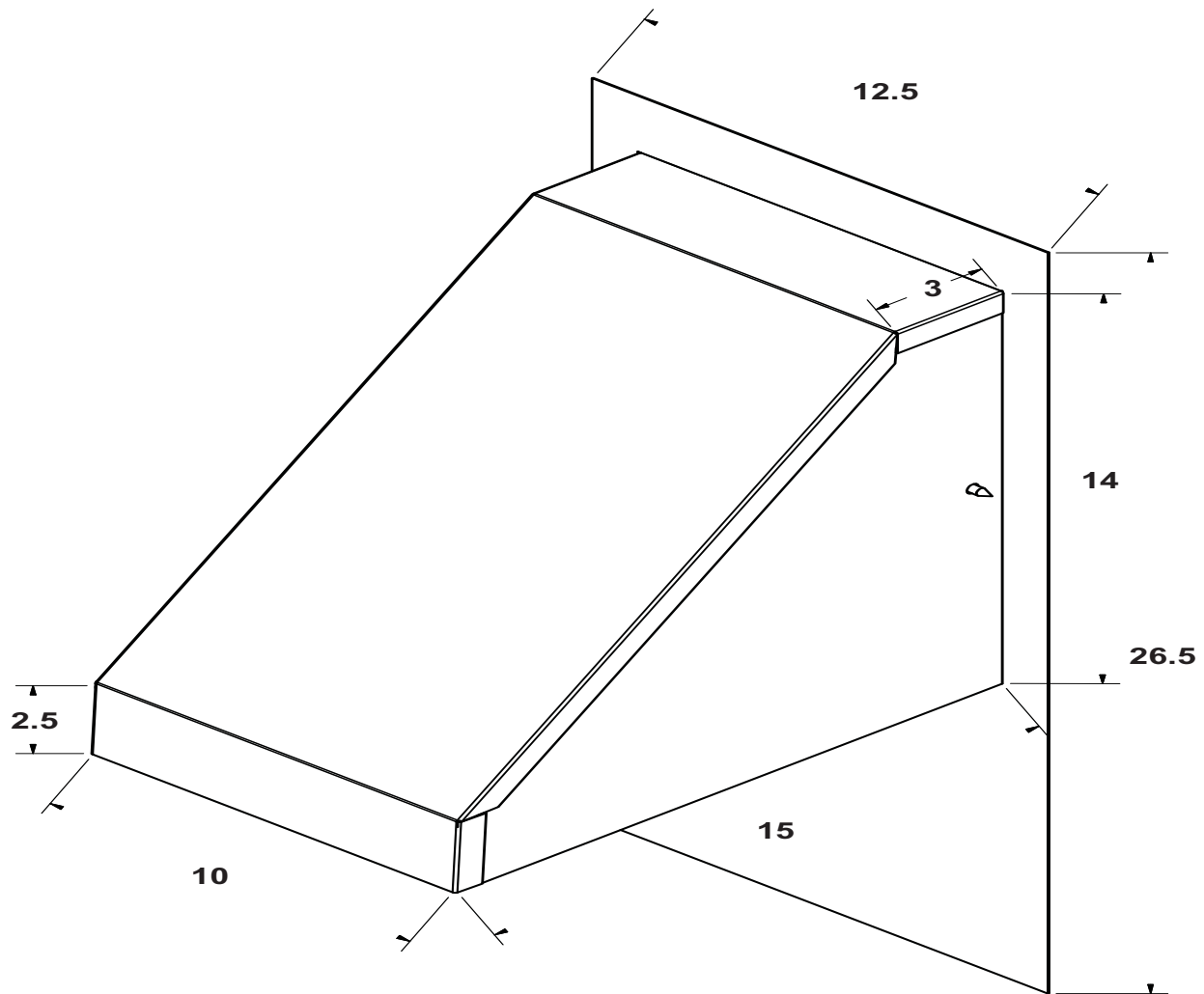

SPECIFICATIONS

MANUAL DAMPER

- PROVIDES UP TO 25% FRESH AIR
- LOCKING SELECTION KNOB PROVIDES CONSTANT OPENING

MOTORIZED DAMPER

- 24VAC DAMPER MOTOR WITH SPRING RETURN
- FULLY ASSEMBLED AND FACTORY WIRED

FITS ALL 3 - 6 TON PACKAGE UNITS IN ALL FUELS
ALL DAMPERS PAINTED TO MATCH THE UNIT