

DNECONGS3672 INSTALLATION AND OPERATION GUIDE

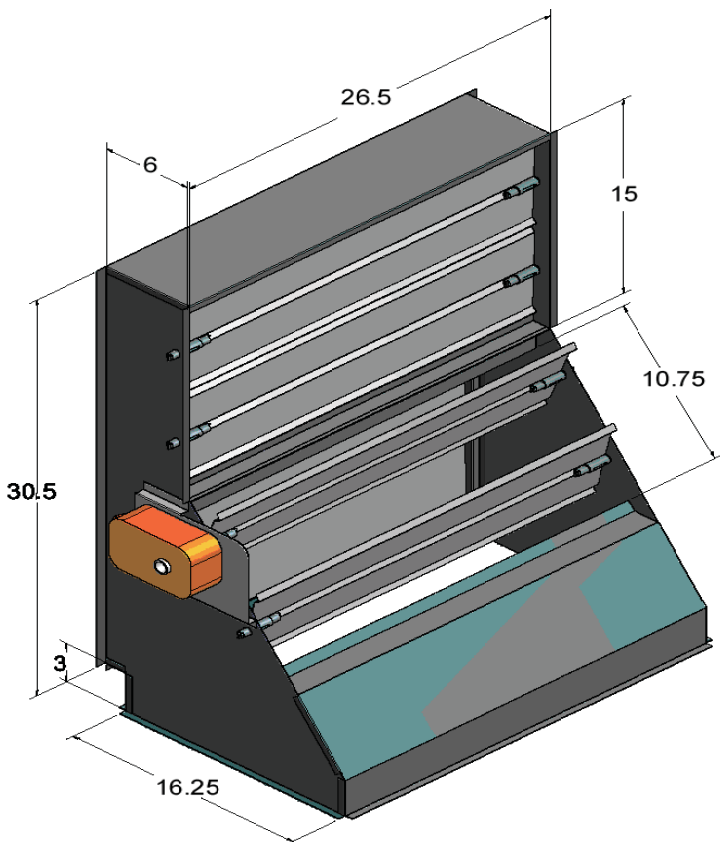

ECONOMIZER 101

Economizers are designed to provide “free” air conditioning when outside conditions are appropriate. When the outside air is cool and dry enough, the economizer automatically opens to introduce the cool air to the interior space, thereby eliminating the need to run the air conditioning compressor.

If the outside air becomes too warm or humid, the economizer automatically closes the fresh air damper and the compressor engages to begin cooling the space mechanically.

If a two stage thermostat is used it is possible to use a combination of economizer and mechanical cooling to condition the space.

The economizer can also be set to allow a minimum amount of fresh air to enter the space when the equipment’s indoor blower is operating.

Economizers are valuable tools to enhance indoor air quality, save energy and prolong the life of the air conditioning equipment.

SEQUENCE OF OPERATION

This sequence assumes employment of a single enthalpy economizer using a two stage thermostat.

1. A call for cooling comes from room thermostat.
2. The enthalpy sensor determines if the atmospheric conditions are conducive for using outside air for cooling. If YES, go to step 3. If NO, or if outdoor air temperature rises above enthalpy set point, go to step 4.
3. The outside air dampers open and modulate to maintain a mixed air temperature (outside air + indoor air) of 53 degrees F. If the outdoor air is insufficient to satisfy the thermostat alone and a second stage of cooling is required, the compressor starts and works in conjunction with the economizer

to cool the space. (Go to step 5.)

4. Outdoor air dampers open to minimum position and the compressor engages to provide mechanical cooling.
5. When the thermostat is satisfied the outside air dampers return to a closed position.

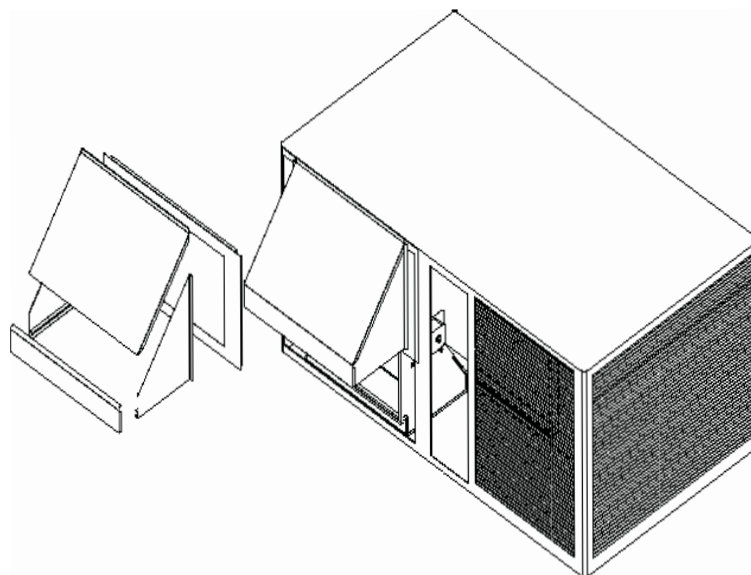
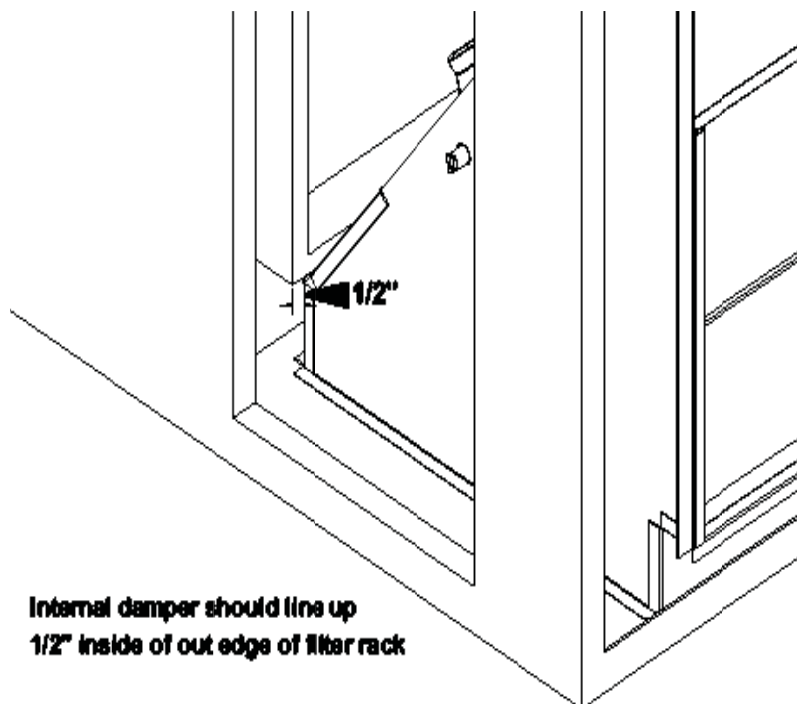

Figure 1

INSTALLATION

1. Open carton and inspect contents for shortages and damage.
2. Remove large evaporator access panel from package unit and discard. Remove the smaller filter access panel.
3. Slide internal damper rack into the opening.
4. Line the left edge of the damper assembly up with the inside flange of the internal filter rack. The left edge of the economizer should be 1/2” from the left edge of the filter rack. (See FIGURE 2 below)



**Internal damper should line up
1/2” inside of out edge of filter rack**

Figure 2

5. Plug 6-pin economizer plug into matching 6-pin plug in the unit.

NOTE: Ensure neither the wire nor the plugs interfere with the movement of the dampers during operation.

6. Install bottom portion of the new access panel on the unit.
7. Install top portion of the new access panel on the unit.
8. Secure access panels to economizer with screws provided.
9. Assemble the barometric relief hood and the fresh air hoods with the screws provided. Be sure to install the mist eliminators before installing the front filter access piece. (See FIGURE 3)
10. Refer to psychrometric chart included with controller check out literature to determine the A, B, C, or D setting for the controller. The factory setting is the D position.
11. Use the following equation to determine the minimum position setting on the controller. The factory setting is closed or full CCW.
12. Install barometric relief hood.
13. Install the fresh air hood and weatherproof.
14. Replace filter access panel on unit.

MINIMUM SET POINT EQUATION

$$(To \times OA) + (Tr \times RA) = Tm$$

To = Outdoor air temperature

OA= Percent of outdoor air

Tr = Return air temperature

RA= Percent of return air

Tm= Resulting mixed air temperature

Example:

Fresh air required is 10% outdoor air.

Outdoor air temperature is 60 degrees F.

Return air temperature is 75 degrees F.

$$(0.1 \times 60) + (0.9 \times 75) = 6.0 + 67.5 = 73.5$$

Mixed air temperature will be 73.5 degrees F when the OA is 60 degrees F and the RA is 75 degrees F with 10% outdoor air.

CONTENTS

1	Damper rack w/ economizer controls
2	Fresh air hood sides
1	Fresh air hood top
1	Fresh air hood filter access
2	Barometric relief hood sides
1	Barometric relief hood top
1	Barometric relief hood filter access
1	Fresh air mist eliminator
1	Barometric relief hood birdscreen
1	Screw package and control jumpers
1	Bottom access panel
1	Top access panel

ACCESSORIES / CAPABILITIES

Dual Enthalpy - Requires an additional C7400 enthalpy control installed in the return air duct.

Demand Control Ventilation - Requires a CO2 sensor.

Power Exhaust - DNPE3672 power exhaust used in applications where barometric relief is not sufficient.

Remote Minimum Positioner - For applications requiring minimum position adjustments inside the conditioned space.

Important Notes

Please see enclosed brochure for Honeywell component trouble shooting instructions.

Controller is factory set for power exhaust to engage when the dampers are 70% open.

The fresh air mist eliminator should be flushed periodically with warm soapy water.

A two stage thermostat is recommended with this accessory.

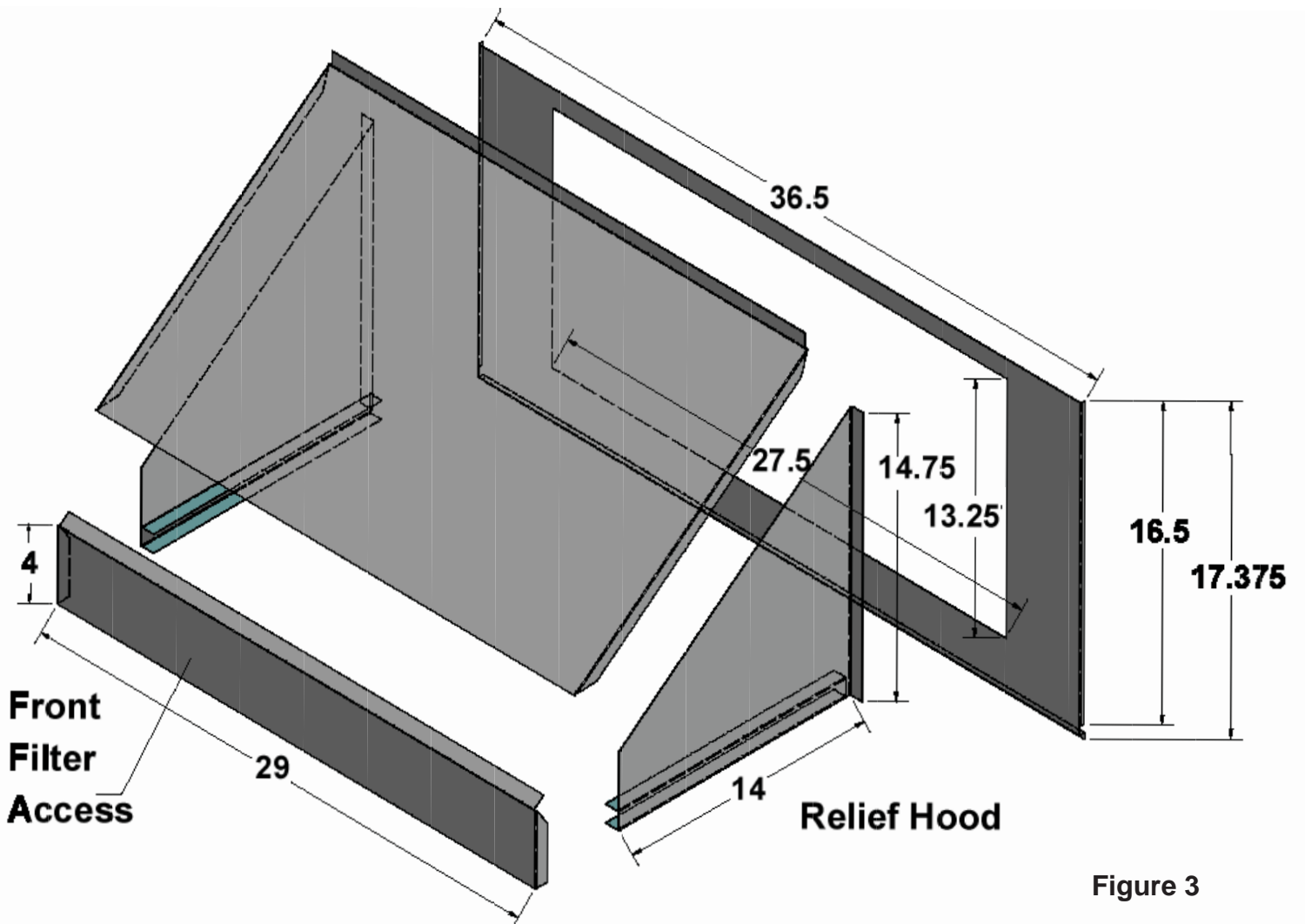
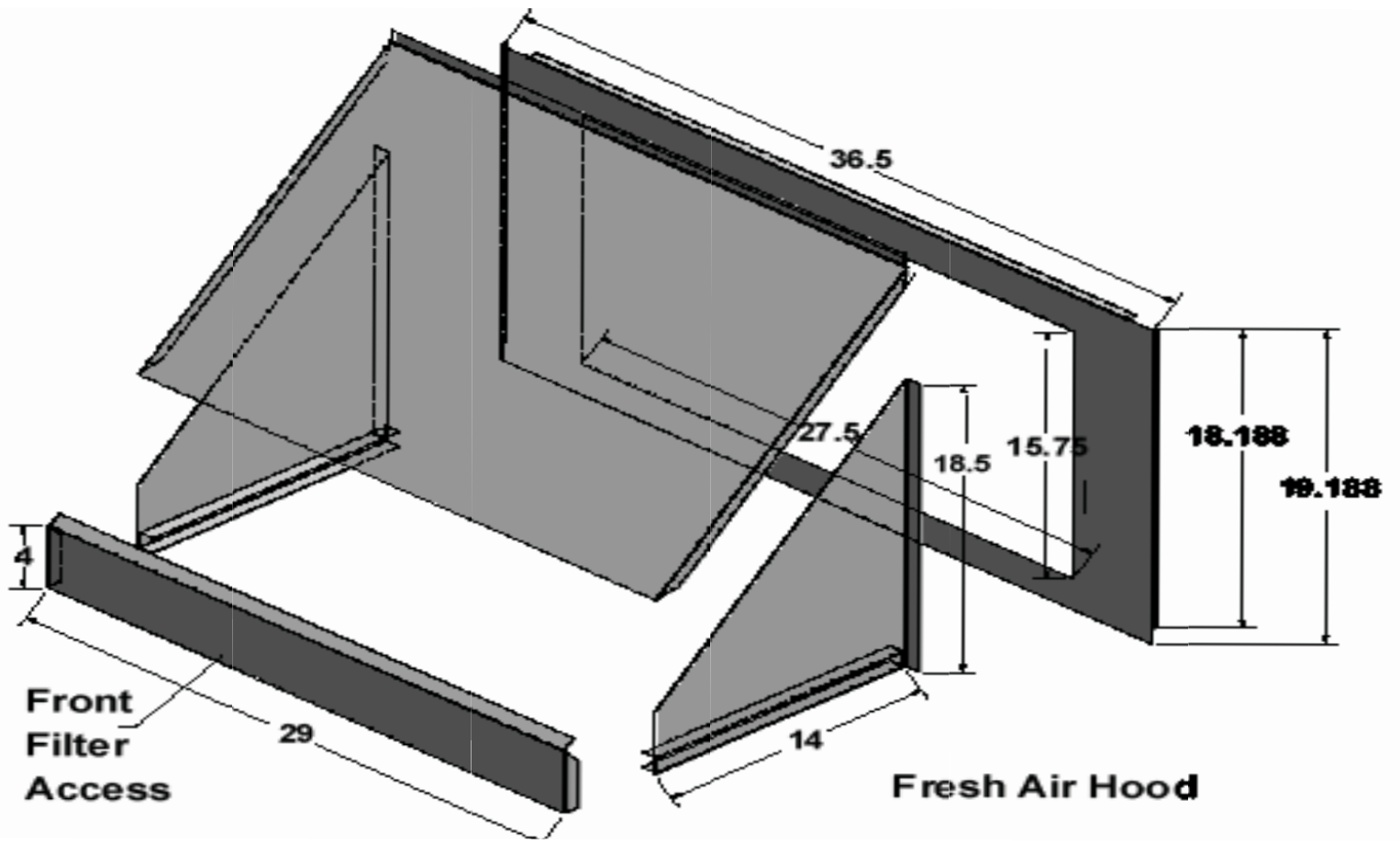
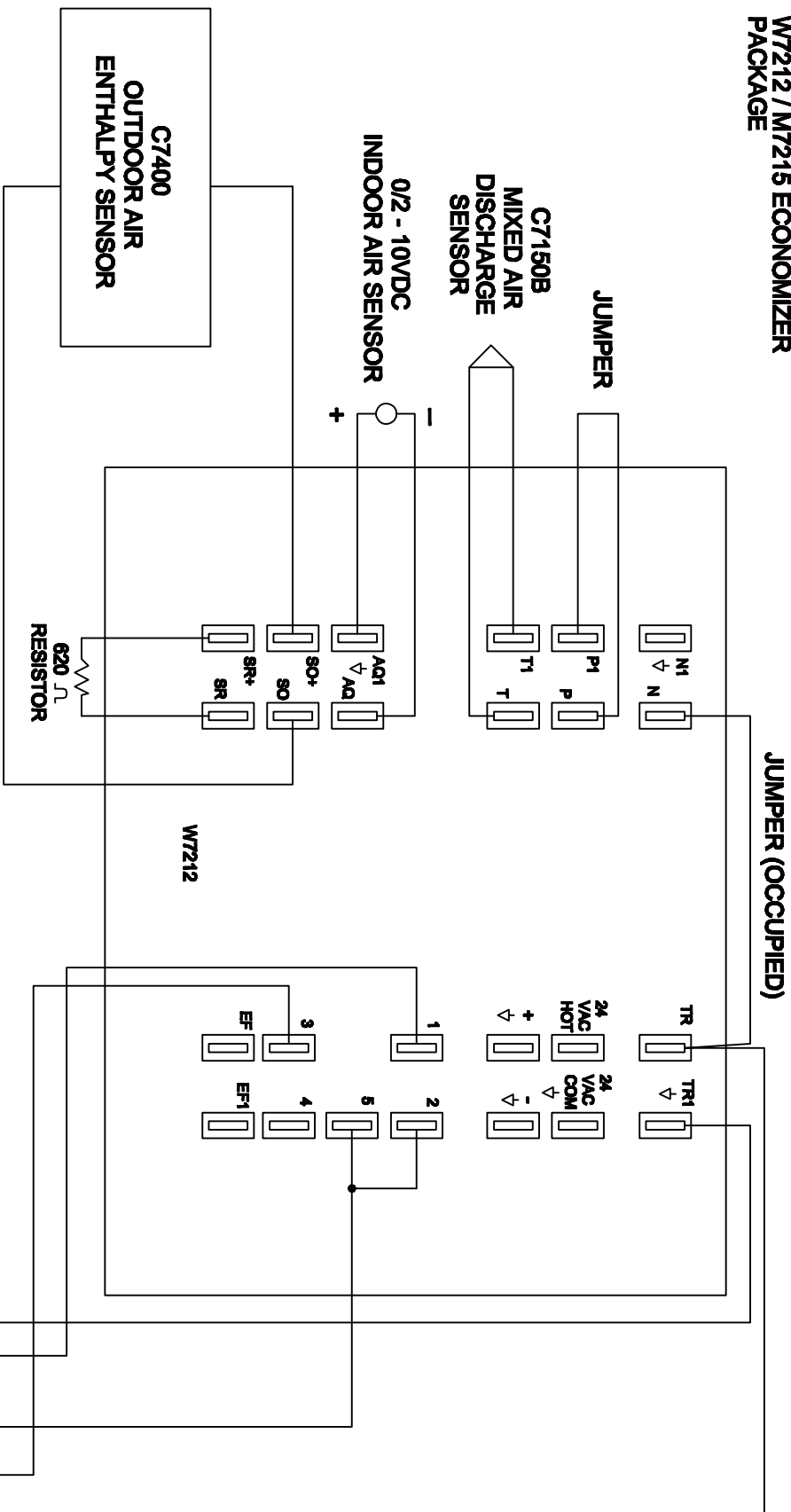

Figure 3

**GOODMAN GAS PACK WITH
W7212 / M7215 ECONOMIZER
PACKAGE**



COLOR CODES

①	(P) PURPLE
②	(Y/R) YELLOW / RED
③	(G) GREEN
④	(BL) BLUE
⑤	(Y) YELLOW

G	③	⑥
Y2 TSTAT	②	⑤
Y1 TSTAT	①	④

Y (CONTACTOR)
COMMON

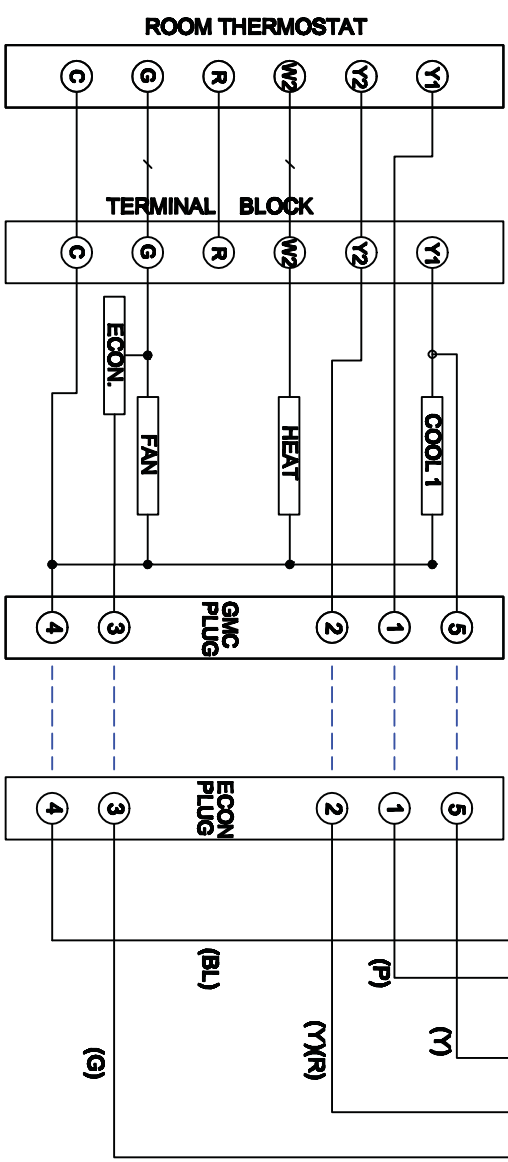

(P)
(Y/R)
(G)
(BL)