

25FD90150 AND 25MFD90150 MANUAL / MOTORIZED FRESH AIR DAMPER

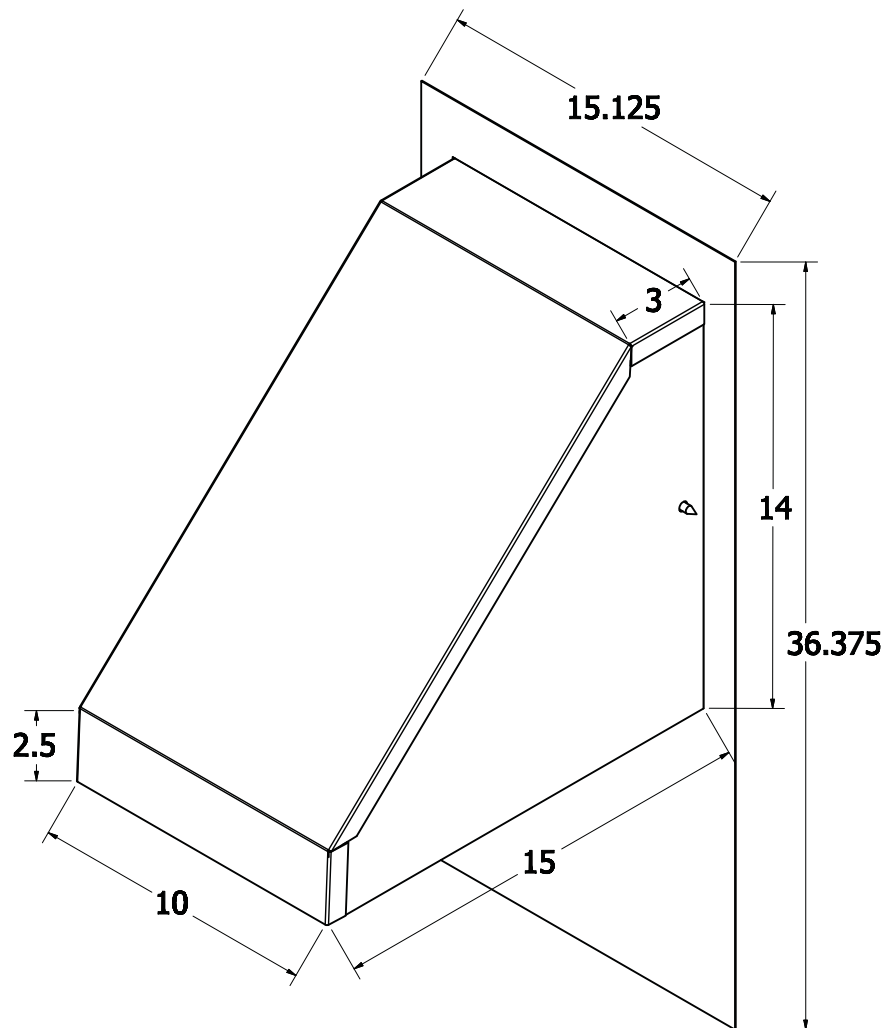

SPECIFICATIONS

MANUAL DAMPER

- PROVIDES UP TO 25% FRESH AIR
- LOCKING SELECTION KNOB PROVIDES CONSTANT OPENING

MOTORIZED DAMPER

- 24VAC DAMPER MOTOR WITH SPRING RETURN
- FULLY ASSEMBLED AND FACTORY WIRED

FITS ALL 7.5 - 12.5 TON PACKAGE UNITS IN ALL FUELS
ALL DAMPERS PAINTED TO MATCH THE UNIT