

DNECONGS150 INSTALLATION AND OPERATION GUIDE

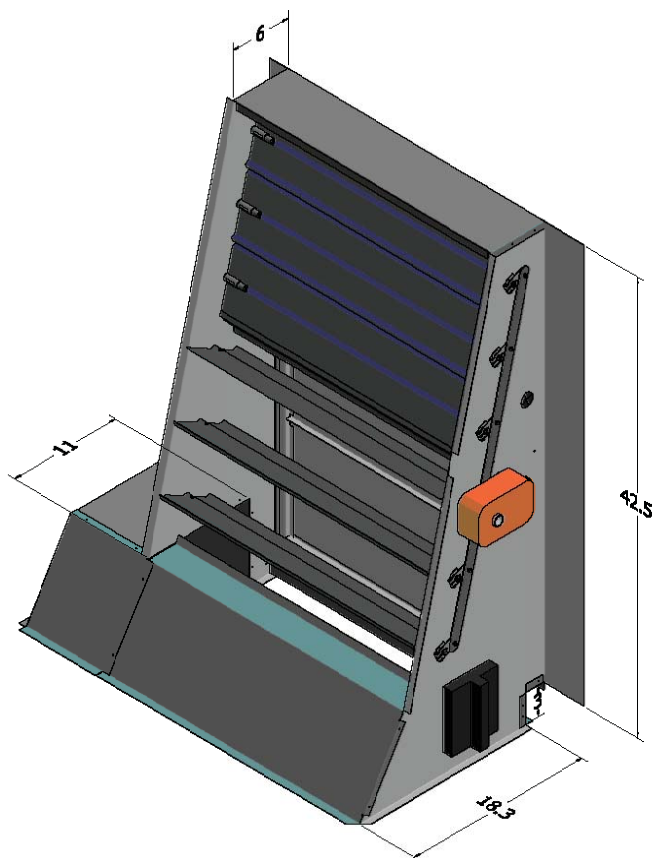

ECONOMIZER 101

Economizers are designed to provide “free” air conditioning when outside conditions are appropriate. When the outside air is cool and dry enough, the economizer automatically opens to introduce the cool air to the interior space, thereby eliminating the need to run the air conditioning compressor.

If the outside air becomes too warm or humid, the economizer automatically closes the fresh air damper and the compressor engages to begin cooling the space mechanically.

If a two stage thermostat is used it is possible to use a combination of economizer and mechanical cooling to condition the space.

The economizer can also be set to allow a minimum amount of fresh air to enter the space when the equipment’s indoor blower is operating.

Economizers are valuable tools to enhance indoor air quality, save energy and prolong the life of the air conditioning equipment.

SEQUENCE OF OPERATION

This sequence assumes employment of a single enthalpy economizer using a two stage thermostat.

1. A call for cooling comes from room thermostat.
2. The enthalpy sensor determines if the atmospheric conditions are conducive for using outside air for cooling. If YES, go to step 3. If NO, or if outdoor air temperature rises above enthalpy set point, go to step 4.
3. The outside air dampers open and modulate to maintain a mixed air temperature (outside air + indoor air) of 53 degrees F. If the outdoor air is insufficient to satisfy the thermostat alone and a second stage of cooling is required, the first stage compressor starts and works in conjunction with the economizer

to cool the space. (Go to step 5.)

4. Outdoor air dampers open to minimum position and the compressor engages to provide mechanical cooling.
5. When the thermostat is satisfied the outside air dampers return to a closed position.

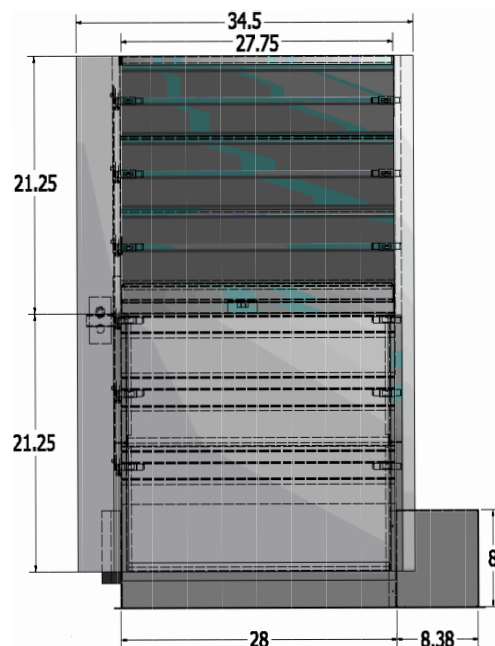
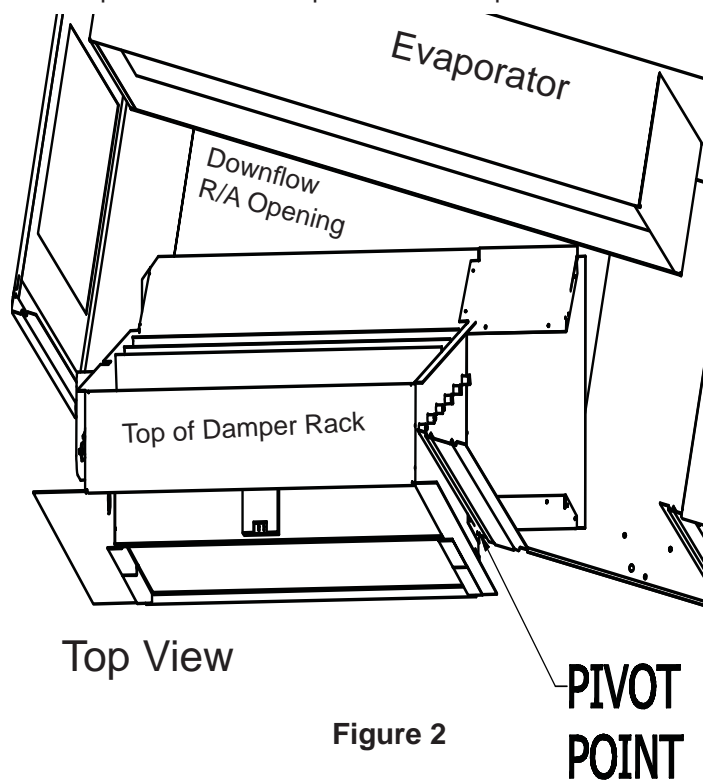

Figure 1

INSTALLATION

1. Open carton and inspect contents for shortages and damage.
2. Remove large evaporator access panel from package unit and discard. Remove the smaller filter access panel and the horizontal return air panel.
3. Slide the damper rack into the large opening and rotate the damper in position around the pivot point in Figure 2.
4. Slide the dampers in the opening until the front flanges are flush with the corner post and divider post between the filter access panel and the evaporator access panel.



Top View

Figure 2

**PIVOT
POINT**

CONTENTS

1	Damper rack w/ economizer controls
2	Fresh air hood sides
1	Fresh air hood top
1	Fresh air hood filter access
2	Barometric relief hood sides
1	Barometric relief hood top
1	Barometric relief hood filter access
2	Mist eliminator
1	Access Panel
1	Screw package and control jumpers
1	Installation Instructions and Component Manual

5. From the horizontal return opening, plug 9-pin economizer plug into matching 9-pin plug in the unit.

NOTE: Ensure neither the wire nor the plugs interfere with the movement of the dampers during operation.

- 6. Install the new access panel on the unit.
- 7. Secure access panel to the unit with the screws provided.
- 8. Assemble the barometric relief hood and the fresh air hoods with the screws provided. Be sure to install the mist eliminators before installing the front filter access piece. (See FIGURE 3)
- 10. Refer to psychrometric chart included with controller check out literature to determine the A, B, C, or D setting for the controller. The factory setting is the D position.
- 11. Use the minimum set point equation (see below) to determine the minimum position setting on the controller. The factory setting is closed or full CCW.
- 12. Install barometric relief hood with screws provided through access panel and economizer.
- 13. Install the fresh air hood with the screws provided through the access panel and economizer and weatherproof both hoods.
- 14. Replace filter access panel and the horizontal return panel on the unit.

MINIMUM SET POINT EQUATION

(To X OA) + (Tr X RA) = Tm
To = Outdoor air temperature
OA= Percent of outdoor air
Tr = Return air temperature
RA= Percent of return air
Tm= Resulting mixed air temperature

Example:
 Fresh air required is 10% outdoor air.
 Outdoor air temperature is 60 degrees F.
 Return air temperature is 75 degrees F.
 $(0.1 \times 60) + (0.9 \times 75) =$
 $6.0 + 67.5 = 73.5$
 Mixed air temperature will be 73.5 degrees F when the OA is 60 degrees F and the RA is 75 degrees F with 10% outdoor air.

ACCESSORIES / CAPABILITIES

- Dual Enthalpy - Requires an additional C7400 enthalpy control installed in the return air duct.
- Demand Control Ventilation - Requires a CO2 sensor.
- Power Exhaust - DNPE3672 power exhaust used in applications where barometric relief is not sufficient.
- Remote Minimum Positioner - For applications requiring minimum position adjustments inside the conditioned space.

Important Notes

If Power Exhaust or Demand Control Ventilation are not utilized in the system ensure that the DCV Set and DCV Max pots are turned full counter-clockwise

Please see enclosed brochure for Honeywell component trouble shooting instructions.

Controller is factory set for power exhaust to engage when the dampers are 70% open.

The fresh air mist eliminator should be flushed periodically with warm soapy water.

A two stage thermostat is recommended with this accessory.

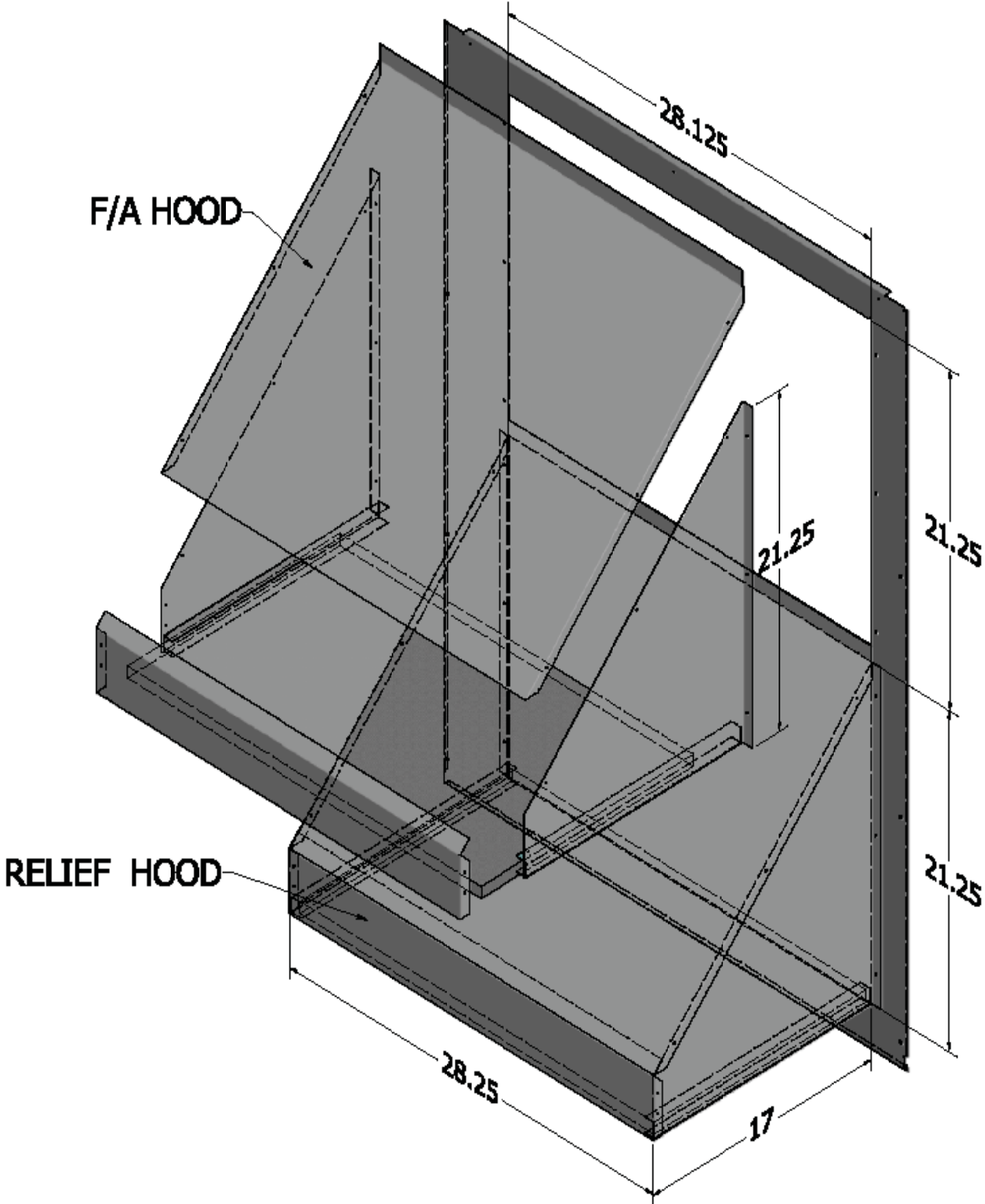
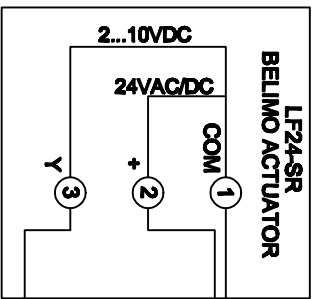

Figure 3

**GOODMAN GAS PACK WITH
W7212 / LF24-SR ECONOMIZER
PACKAGE**

JUMPER (OCCUPIED)



JUMPER
C7150B
MIXED AIR
DISCHARGE
SENSOR

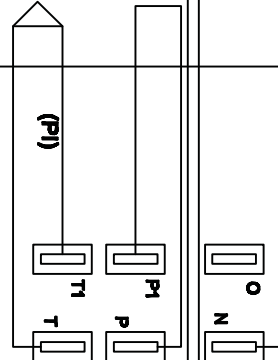

**0/2 - 10VDC
INDOOR AIR SENSOR**

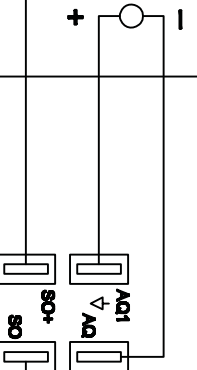

**C7400
OUTDOOR AIR
ENTHALPY SENSOR**

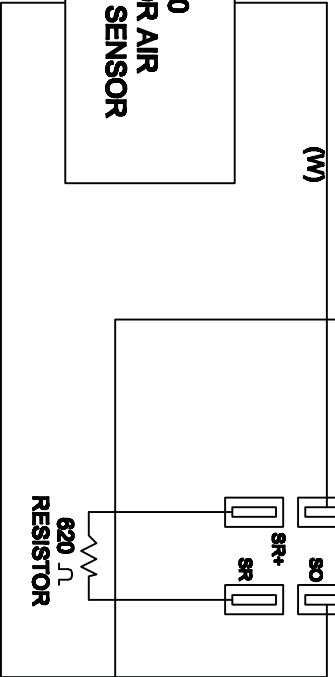

COLOR CODES

- ① (Y) YELLOW
- ② (P) PURPLE
- ③ (P) PURPLE
- ④ (Y/R) YELLOW/RED
- ⑤ (B) BLUE
- ⑥ (G) GREEN
- ⑧ (P) PINK
- (M) WHITE

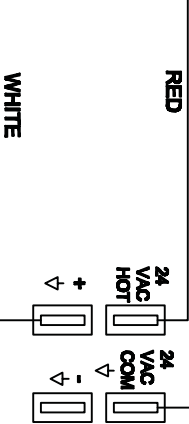
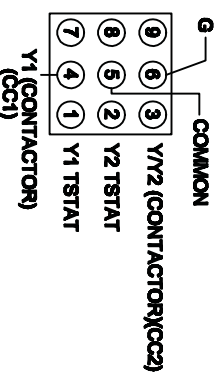

W7212

**620 Ohm
RESISTOR**

ROOM THERMOSTAT

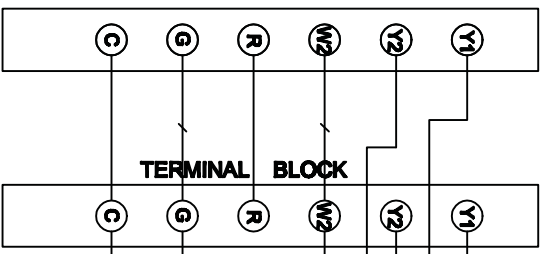

TERMINAL BLOCK

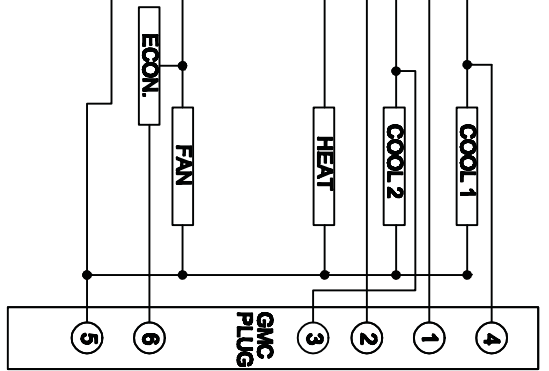

GMC PLUG

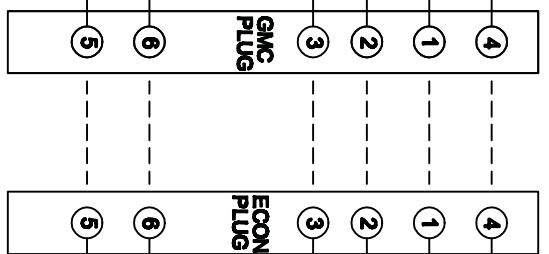

ECON PLUG

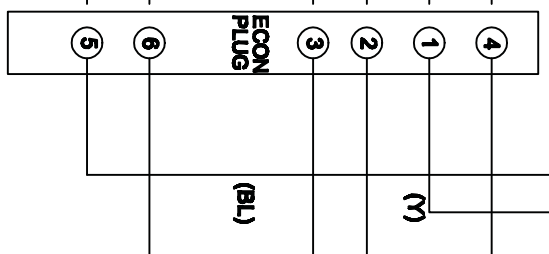

(Y/R) (M) (P) (P) (BL) (G)