

HZECONHP90150 INSTALLATION AND OPERATION GUIDE

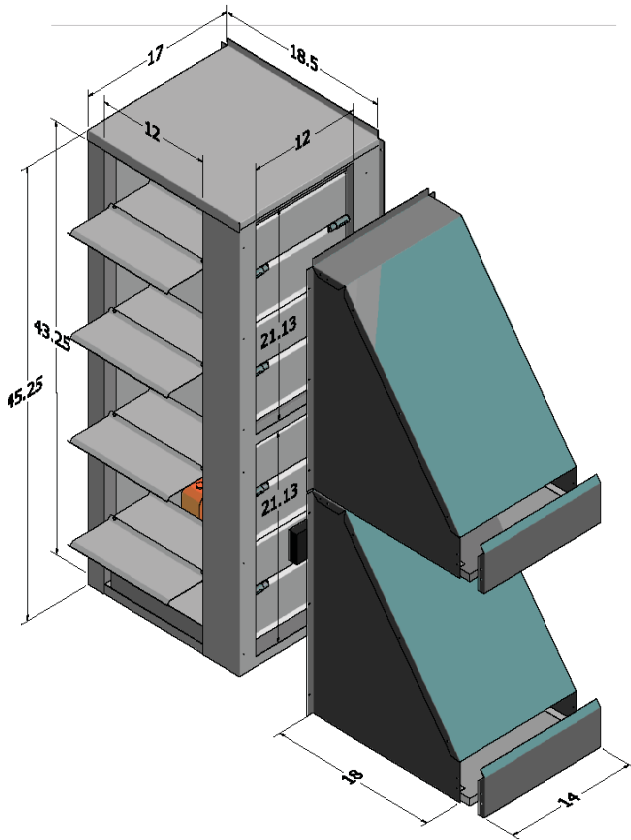

ECONOMIZER 101

Economizers are designed to provide “free” air conditioning when outside conditions are appropriate. When the outside air is cool and dry enough, the economizer automatically opens to introduce the cool air to the interior space, thereby eliminating the need to run the air conditioning compressor.

If the outside air becomes too warm or humid, the economizer automatically closes the fresh air damper and the compressor engages to begin cooling the space mechanically.

If a two stage thermostat is used it is possible to use a combination of economizer and mechanical cooling to condition the space.

The economizer can also be set to allow a minimum amount of fresh air to enter the space when the equipment’s indoor blower is operating.

Economizers are valuable tools to enhance indoor air quality, save energy and prolong the life of the air conditioning equipment.

SEQUENCE OF OPERATION

This sequence assumes employment of a single enthalpy economizer using a two stage thermostat.

1. A call for cooling comes from room thermostat.
2. The enthalpy sensor determines if the atmospheric conditions are conducive for using outside air for cooling. If YES, go to step 3. If NO, or if outdoor air temperature rises above enthalpy set point, go to step 4.
3. The outside air dampers open and modulate to maintain a mixed air temperature (outside air + indoor air) of 53 degrees F. If the outdoor air is insufficient to satisfy the thermostat alone and a second stage of cooling is required, the compressor starts and works in conjunction with the economizer

to cool the space. (Go to step 5.)

4. Outdoor air dampers open to minimum position and the compressor engages to provide mechanical cooling.
5. When the thermostat is satisfied the outside air dampers return to a closed position.

INSTALLATION

1. Open carton and inspect contents for shortages and damage.
2. Remove the large evaporator access panel.
3. Remove the horizontal return air opening cover and secure it over the downflow return opening per unit installation instructions.
4. Feed the wiring harness through the return air opening.

NOTE: Ensure that the wiring harness is inside the return air opening and that no part of it is caught between the economizer and the side of the unit.

5. Attach the economizer to the unit over the horizontal return air opening by sliding the top flange of the economizer under the flange on the top of the unit and securing with sheet metal screws. Weatherproof the seam where the economizer and unit attach using silicone or other approved sealant.

NOTE: Ensure neither the wire nor the plugs interfere with the movement of the dampers during operation.

6. Remove the economizer plug attached to the unit and hardwire the economizer to the according to the wiring diagram attached.
7. Refer to psychrometric chart included with controller check out literature to determine the A, B, C, or D setting for the controller. The factory setting is the D position.
8. Use the minimum set point equation to determine the minimum position setting on the controller. The factory setting is closed or full CCW on the controller.
9. Replace the evaporator access door.
10. Attach field supplied duct to return air duct opening on the economizer.

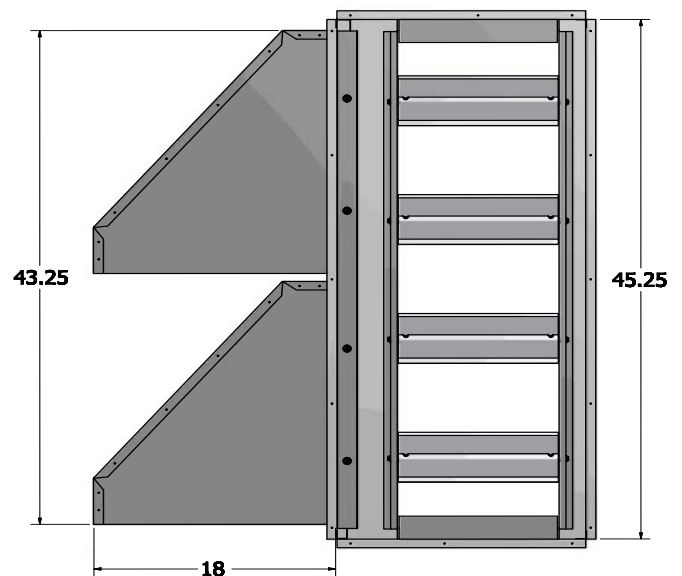

ACCESSORIES / CAPABILITIES

Dual Enthalpy - Requires an additional C7400 enthalpy control installed in the return air duct.

Demand Control Ventilation - Requires a CO2 sensor.

Power Exhaust - DNPE3672 power exhaust used in applications where barometric relief is not sufficient.

Remote Minimum Positioner - For applications requiring minimum position adjustments inside the conditioned space.

Duct mounted barometric relief damper.

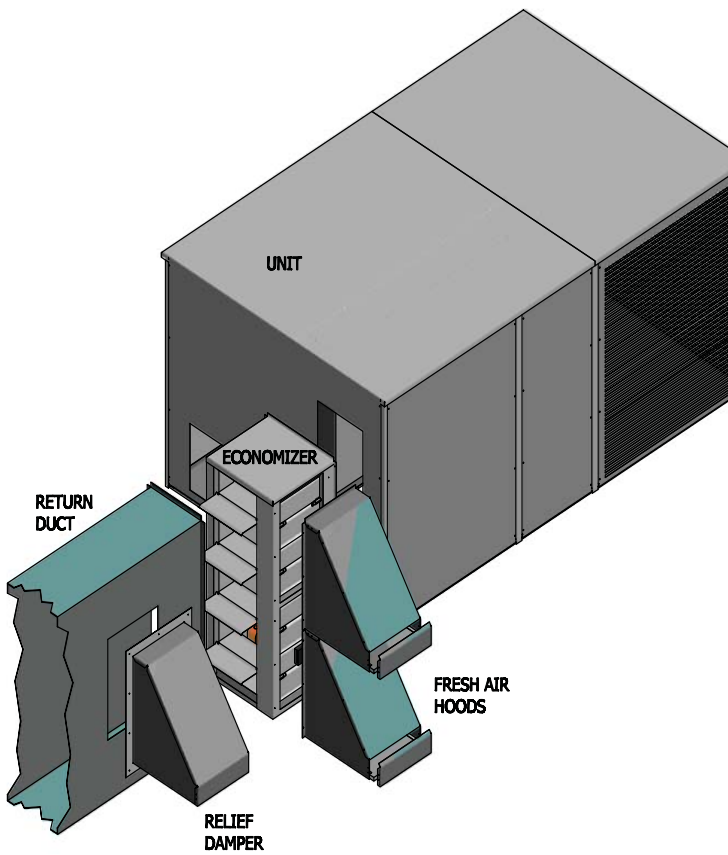

MINIMUM SET POINT EQUATION

$$(To \times OA) + (Tr \times RA) = Tm$$

To = Outdoor air temperature

OA= Percent of outdoor air

Tr = Return air temperature

RA= Percent of return air

Tm= Resulting mixed air temperature

Example:

Fresh air required is 10% outdoor air.

Outdoor air temperature is 60 degrees F.

Return air temperature is 75 degrees F.

$$(0.1 \times 60) + (0.9 \times 75) =$$

$$6.0 + 67.5 = 73.5$$

Mixed air temperature will be 73.5 degrees F when the OA is 60 degrees F and the RA is 75 degrees F with 10% outdoor air.

Important Notes

- If Power Exhaust or Demand Control Ventilation is not utilized ensure that the EXH, DCV Max and DCV Set pots are full counterclockwise.
- The economizer will open to the minimum position setting during heating unless the mixed air temperature drops below 45F. It will re-energize when the mixed air temperature reaches 48F. See controls brochure for more details.
- Please see enclosed brochure for Honeywell component trouble shooting instructions.
- Controller is factory set for power exhaust to engage when the dampers are 70% open.
- The fresh air mist eliminator should be flushed periodically with warm soapy water.
- A two stage thermostat is recommended with this accessory.

CONTENTS

Return Air/Fresh Air Damper Section

Fresh Air Hood Left Sides (2)

Fresh Air Hood Right Sides (2)

Fresh Air Hood Tops (2)

Fresh Air Hood Front Filter Access (2)

Mist Eliminators (2)

Screw Package

Installation Instructions and Component Literature

**GOODMAN HEAT PUMP WITH
W7214 / LF24-SR ECONOMIZER
PACKAGE**

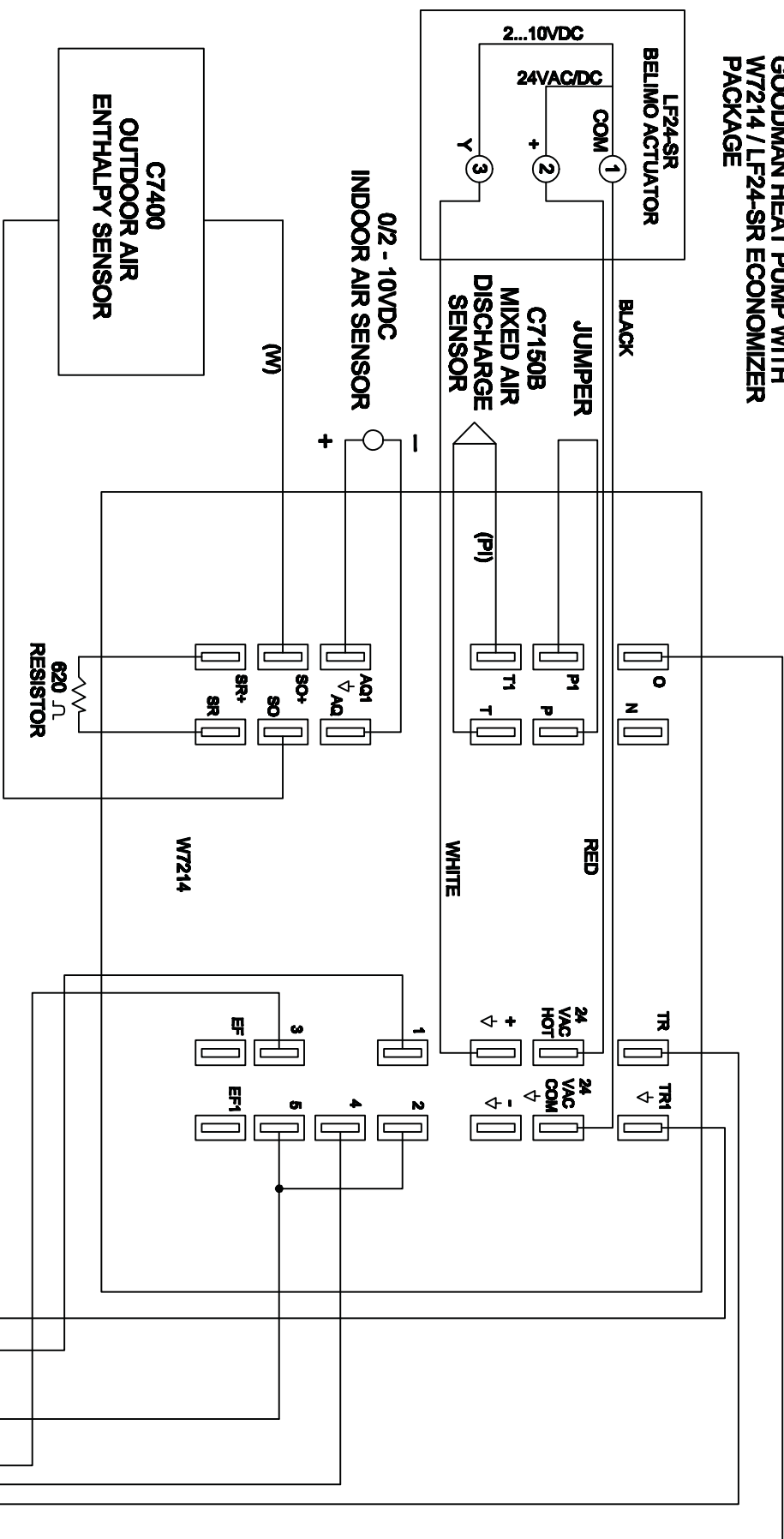

- COLOR CODES**
- ① (Y) YELLOW
 - ② (P) PURPLE
 - ③ (P) PURPLE
 - ④ (Y/R) YELLOW/RED
 - ⑤ (B) BLUE
 - ⑥ (G) GREEN
 - ⑦ (O) ORANGE
 - ⑧ (P) PINK
 - (W) WHITE

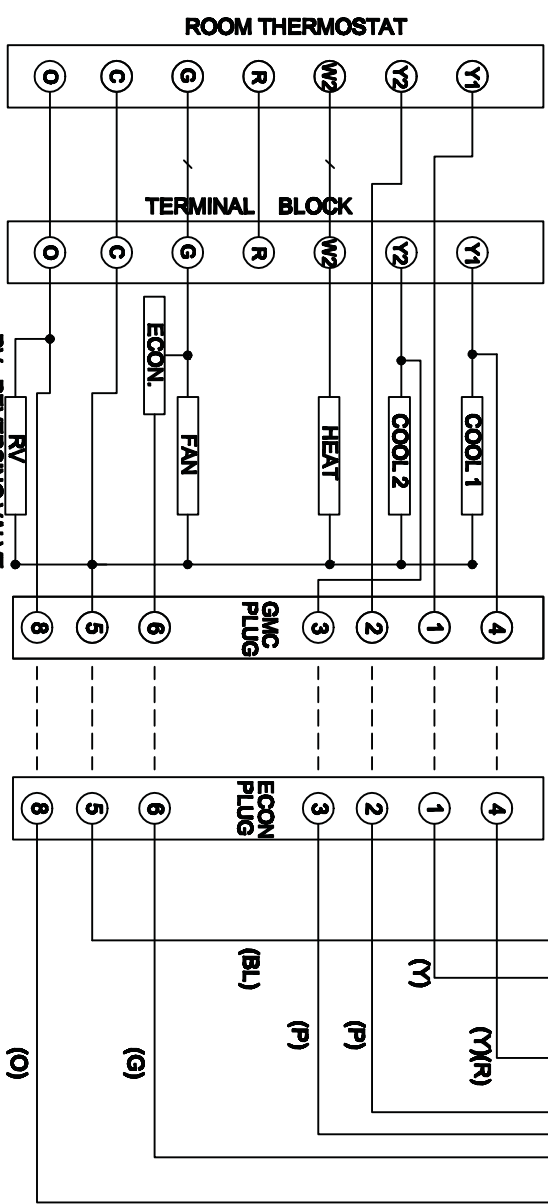
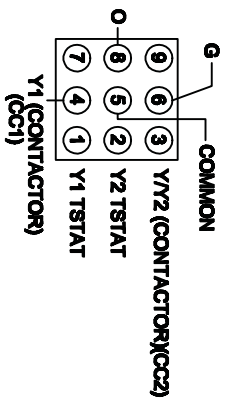

**RV - REVERSING VALVE
(ENERGIZED IN COOLING MODE)**