



**Installation Instructions for PGED090/102-5A & PGED120/180-5A  
DOWNFLOW ECONOMIZERS  
FOR GOODMAN PGC(PCC)090-180 PACKAGE UNITS**

**Description:** The PGED090/102-5 & PGED120/180-5 downflow economizers are designed for the Goodman PGB(PCB) 7-1/2 through 15 ton package units.

These economizers are designed to provide free air conditioning when outside conditions are appropriate. When the outside air is cool and dry enough, the economizer automatically opens to circulate this cool air, thereby eliminating the need to run the air conditioning compressor. This enables the building owner to lower his electrical costs and increase the life of the equipment. If the outside air becomes too warm or humid, the enthalpy control automatically closes the fresh air damper and the compressor begins operation. The economizer is fully modulating and therefore will automatically mix the fresh air and the return air proportionally to get maximum energy savings.

A single or two stage room thermostat can be utilized to control the unit and the economizer. (Recommend GMC part #'s CHT18-60 for single stage thermostat & CHT90-120 for two stage thermostat or equivalents). When a single stage thermostat is used, during a call for cooling the enthalpy control automatically selects "free" cooling or mechanical cooling depending on outdoor air conditions. If a two stage thermostat is used, first stage "free" cooling or mechanical cooling based on outdoor conditions and the enthalpy setting. If the first stage is in the "free" cooling position and does not keep up with the load, the second stage makes (energizes) mechanical cooling. The two stage thermostat optimizes cooling cost and comfort while taking full advantage of the package unit / economizer combination.

**Installation:**

1. Uncrate economizer. Inspect for damage.  
(NOTE: Report any damage immediately to the freight company.)
2. CAUTION: OPEN DISCONNECT SWITCH TO PREVENT INJURY!
3. Remove filter access panel on evaporator drive side of unit.
4. Remove center panel from back side of unit.
5. Slide economizer into back opening of unit.
  - a. Ensure damper side angle assembly slides in on top of unit side flanges. (See Figure 1).
  - b. Top flange of economizer hood should be inserted under top flange of unit.

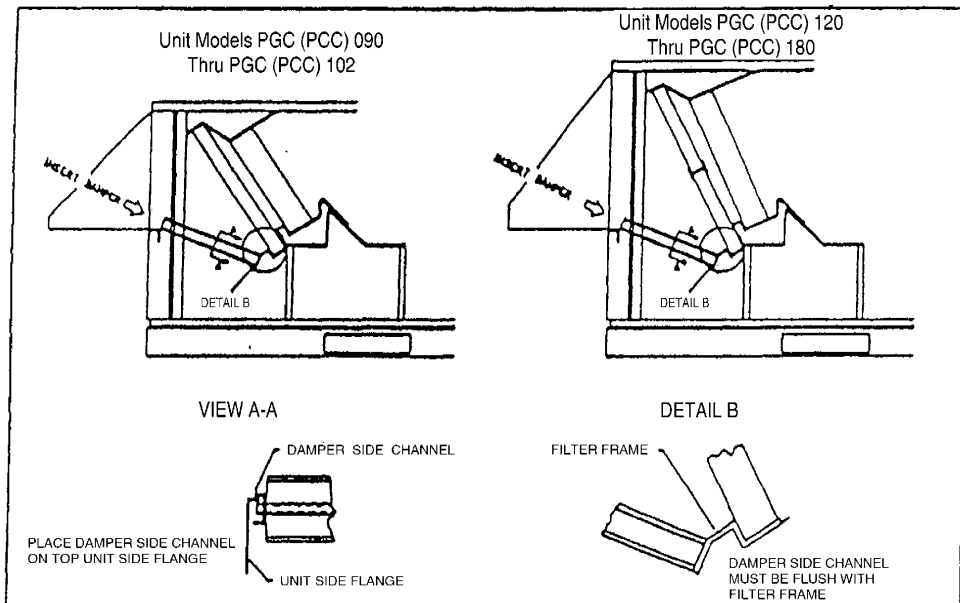
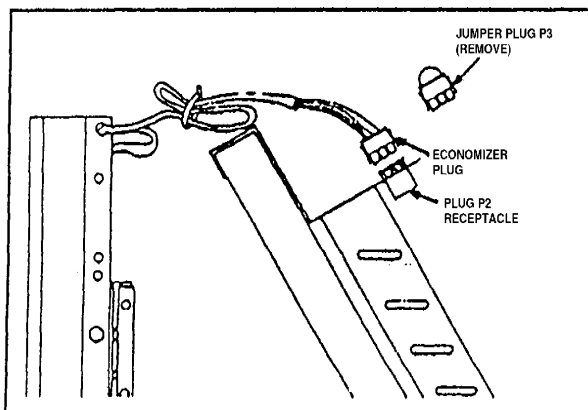

**Figure 1**

6. Route economizer plug harness to unit plug assembly. (See Figure 2). Remove Plug #3 from Plug #2 in unit. Connect the economizer control plug (9 pin male) to unit Plug #2 (9 pin female).

Note: Ensure the wire harness does not interfere with the movement of the dampers during operation. Tie wire harness securely to the wall of the return air compartment.

7. Install Mixed Air Thermister Into round KO in location shown in Figure 3. Route wires included through bushing at drain pan and along evaporator coil assembly using clips provided. Connect two wires to terminal block, TB2, terminals A9 & A10.



**Figure 2**

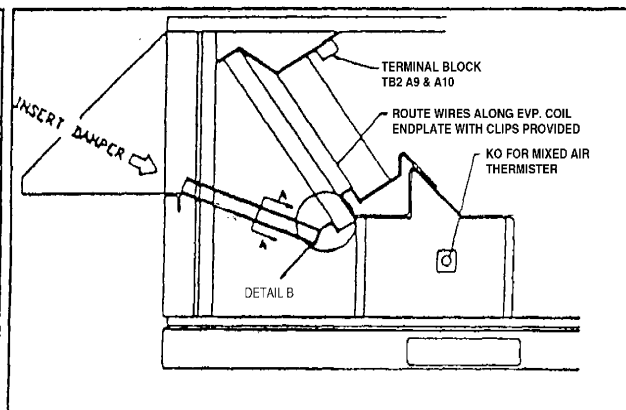

**Figure 3**



8. Install barometric relief hood assembly after economizer hood. Slide top flange of barometric relief hood underneath bottom flange of economizer hood. Secure barometric relief hood to unit (top & bottom) with sheet metal screws. (See Figure 4).

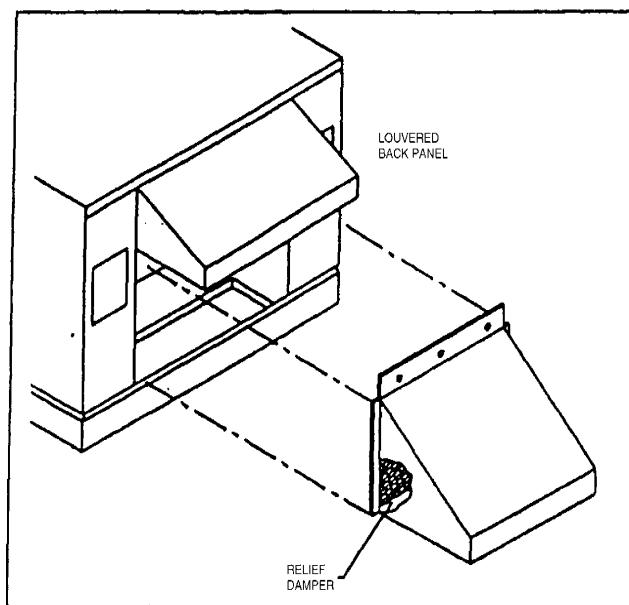

**Figure 4**

9. Seal-water tight around hood.
10. Reset enthalpy and ./ or minimum position potentiometer if setting other than factory setting is desired. (Access controls through filter door opening.)
11. Reinstall filter access panel from Step 3. Discard center panel from Step 4.
12. Close disconnect switch.
13. Check out economizer per control manufacturer's literature.

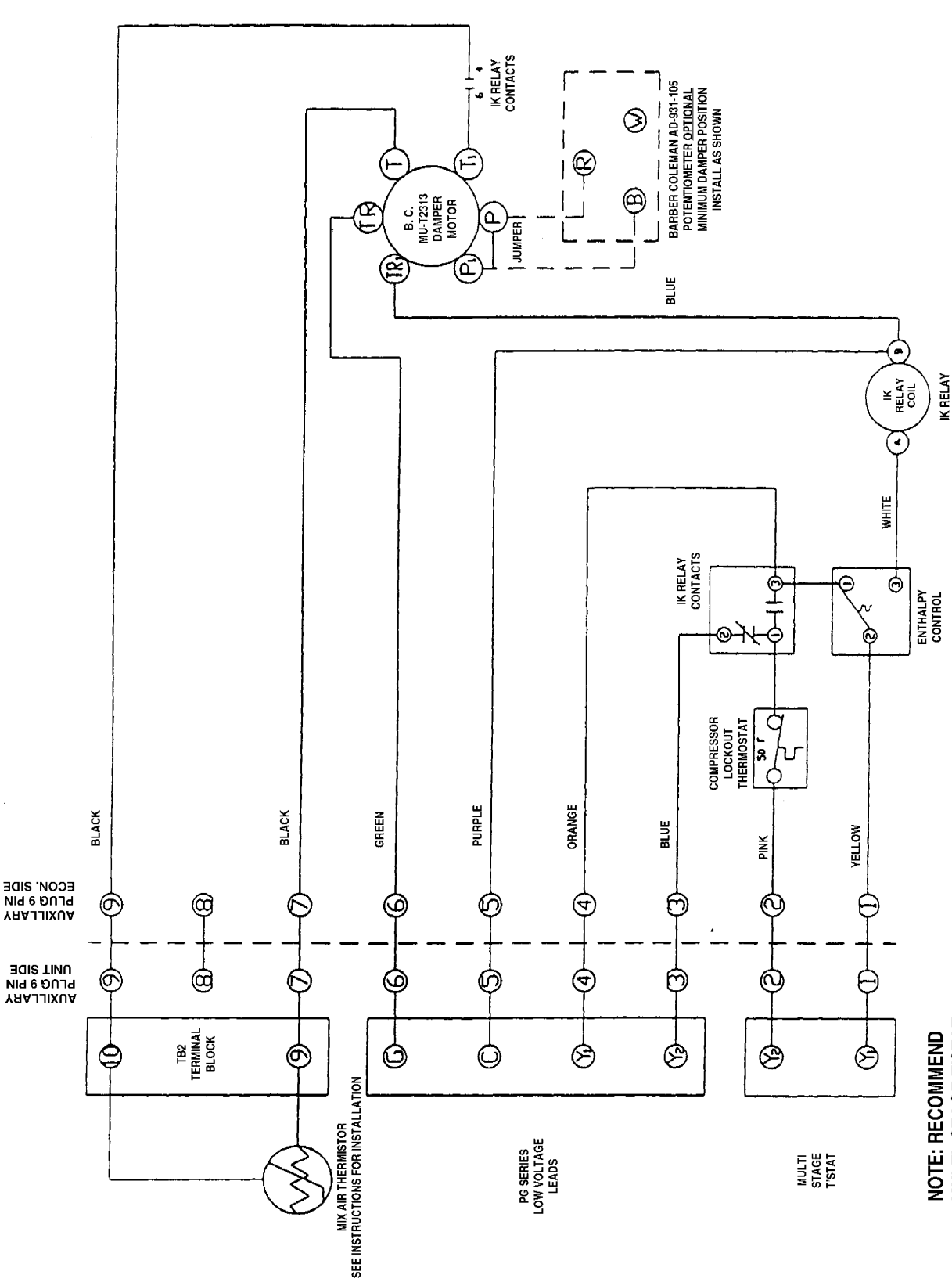

GOODMAN MANUFACTURING CO.  
 MODEL PGED (H) 090/102-5 & 120/180-5  
 ROOF TOP UNITS  
 PGC & PCC SERIES WIRING DIAGRAM

NOTE: RECOMMEND  
 MULTI-STAGE T'STAT  
 GMC # CHT90-120  
 (OR EQUIVALENT)

- FACTORY INSTALLED WIRING
  - - - FIELD INSTALLED WIRING
  - FIELD INSTALLED WIRE NUT
- NOTE: ENTHALPHY CONTROL & RELAYS SHOWN IN NON-ENERGIZED POSITION

McDANIEL METALS CO., INC  
 1318 BUSCHONG STREET  
 HOUSTON, TEXAS 77039  
 VOICE (281) 987-8400  
 FAX (281) 987-9494

# PGHDK090/180-5A BLOCK-OFF KIT

Package Includes;

2- Triangular Block-offs

2- Rectangular Block-offs

1- Screw Package

Remove front panel from unit and install Triangular Block-offs as shown in diagram. Secure with screws provided.

Remove side panels from unit and install Rectangular block-offs over R/A openings as shown in diagram and secure with screws provided. Be sure to replace side panels afterwards.

