

LF24-SR (-S) US



Proportional Damper Actuator, Spring Return Fail-Safe, 24 V for 2 to 10 VDC, or 4 to 20 mA Control Signal.
Output Signal of 2 to 10 VDC for Position Indication.



Technical Data	LF24-SR (-S) US
Power supply	24 VAC \pm 20% 50/60 Hz 24 VDC \pm 10%
Power consumption	running: 2.5 W; holding: 1 W
Transformer sizing	5 VA (class 2 power source)
Electrical connection	LF24-SR US 3 ft, plenum rated cable LF24-SR-SUS 3 ft, 18 GA appliance cables (2) 1/2" conduit connector
Overload protection	electronic throughout 0 to 95° rotation
Operating range Y	2 to 10 VDC, 4 to 20mA
Input impedance	100 k Ω (0.1 mA), 500 Ω
Feedback output U	2 to 10 VDC (max. 0.7 mA) for 95°
Angle of rotation	max. 95°, adjust. with mechanical stop
Torque	35 in-lb [4 Nm]
Direction of rotation	spring: reversible with cw/ccw mounting motor: reversible with built-in switch
Position indication	visual indicator, 0° to 95° (0° is spring return position)
Auxiliary switch (LF24-SR-S US)	1 x SPDT 3A (0.5A) @ 250 VAC, UL listed adjustable 0° to 95° (double insulated)
Running time (nominal)	motor: 150 sec constant, independent of load spring: < 25 sec @ -4°F to +122°F [-20°C to +50°C] < 60 sec @ -22°F [-30°C]
Humidity	5 to 95% RH non-condensing
Ambient temperature	-22°F to +122°F [-30°C to +50°C]
Storage temperature	-40°F to +176°F [-40°C to +80°C]
Housing	NEMA type 2 / IP54
Housing material	zinc coated metal
Agency listings	UL 873 listed; CSA C22.2 No. 24 certified, CE
Noise level	max: running < 30 db (A) spring return 62 db (A)
Servicing	maintenance free
Quality standard	ISO 9001
Weight	LF24-SR 3.1 lbs (1.40 kg) LF24-SR-S 3.2 lbs (1.45 kg)

Torque min. 35 in-lb, for control of air dampers

Application

For proportional modulation of dampers in HVAC systems. Actuator sizing should be done in accordance with the damper manufacturer's specifications.

The actuator is mounted directly to a damper shaft from 3/8" up to 1/2" in diameter by means of its universal clamp, 1/2" shaft centered at delivery. For shafts up to 3/4" use K6-1 accessory. A crank arm and several mounting brackets are available for applications where the actuator cannot be direct coupled to the damper shaft.

The actuator operates in response to a 2 to 10 VDC, or with the addition of a 500 Ω resistor, a 4 to 20 mA control input from an electronic controller or positioner. A 2 to 10 VDC feedback signal is provided for position indication or master-slave applications.

Operation

The LF series actuators provide true spring return operation for reliable fail-safe application and positive close-off on air tight dampers. The spring return system provides consistent torque to the damper with, and without, power applied to the actuator. The LF series provides 95° of rotation and is provided with a graduated position indicator showing 0 to 95°.

The LF24-SR (-S) US uses a brushless DC motor which is controlled by an Application Specific Integrated Circuit (ASIC) and a microprocessor. The microprocessor provides the intelligence to the ASIC to provide a constant rotation rate and to know the actuator's exact fail-safe position. The ASIC monitors and controls the brushless DC motor's rotation and provides a digital rotation sensing function to prevent damage to the actuator in a stall condition. The actuator may be stalled anywhere in its normal rotation without the need of mechanical end switches. Power consumption is reduced in holding mode.

The LF24-SR-S US version is provided with 1 built-in auxiliary switch. This SPDT switch is provided for safety interfacing or signaling, for example, for fan start-up. The switching function is adjustable between 0° and 95°. The auxiliary switch in the LF24-SR-S US is double insulated so an electrical ground in not necessary.

Dimensions [All numbers in brackets are in millimeters.]

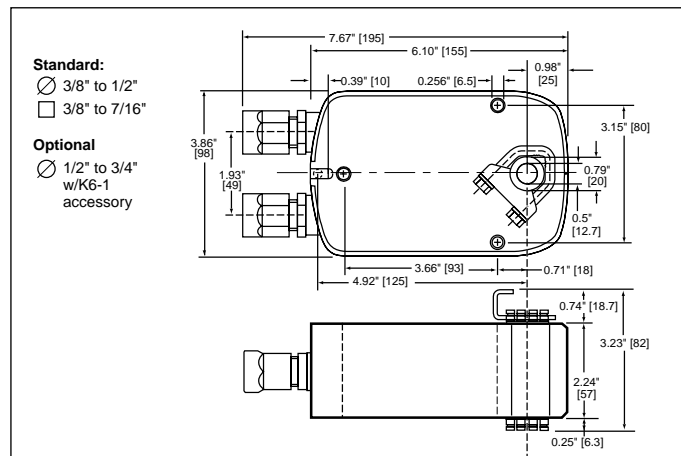

Proportional Damper Actuator, Spring Return Fail-Safe, 24 V for 2 to 10 VDC, or 4 to 20 mA Control Signal. Output Signal of 2 to 10 VDC for Position Indication.

Accessories

AV 10-18	Shaft extension (K6-1 is required)
IND-LF	Damper position indicator
K6-1	Universal clamp for up to 3/4" diameter shafts
KH-LF	Crankarm for up to 1/2" round shaft
SGA24	Min. and/or man. positioner in NEMA 4 housing
SGF24	Min. and/or man. positioner for flush panel mounting
Tool-06	8mm and 10 mm wrench
ZG-LF2	Crankarm adaptor kit for LF
ZG-112	Mounting bracket for Honeywell Mod IV, M6415 type actuators, and new installations
ZG-LF112	Crankarm adaptor kit for Honeywell Mod IV, M6415 type actuators, and new installations
ZG-R01	500Ω resistor for 4 to 20 mA control signal
ZS-100	Weather shield (metal)
ZS-150	Weather shield (polycarbonate)
ZS-260	Explosion-proof housing

Note: When using LF24-SR (-S) US actuators, only use accessories listed on this page.

Wiring Diagrams

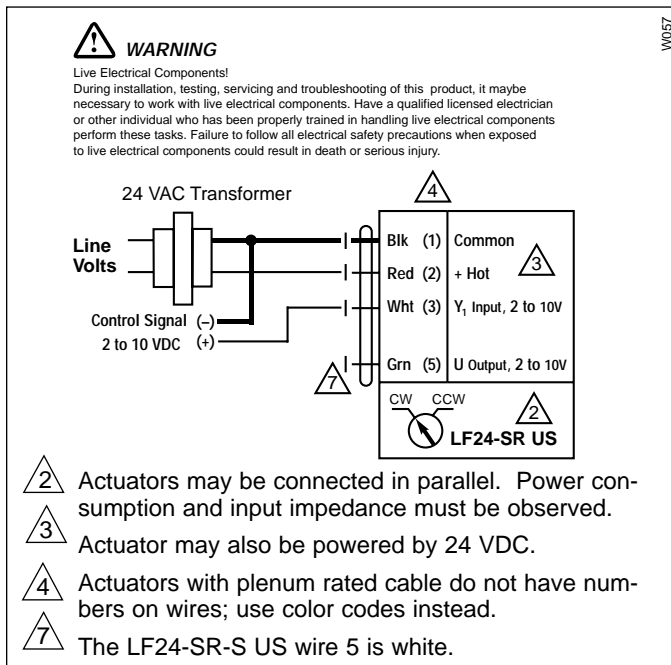

2 to 10 VDC control of LF24-SR (-S) US

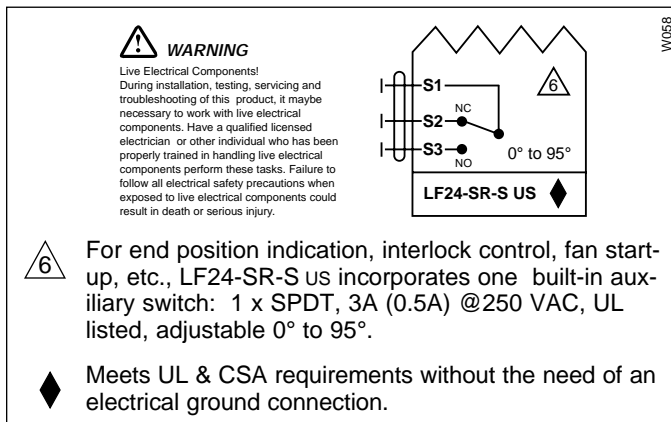

Auxiliary switch of LF24-SR-S US

LF24-SR (-S) US Typical Specification

Spring return control damper actuators shall be direct coupled type which require no crankarm and linkage and be capable of direct mounting to a shaft up to a 3/4" diameter and center a 1/2" shaft. The actuator must provide proportional damper control in response to a 2 to 10 VDC or, with the addition of a 500Ω resistor, a 4 to 20 mA control input from an electronic controller or positioner. The actuators must be designed so that they may be used for either clockwise or counterclockwise fail-safe operation. Actuators shall use a brushless DC motor controlled by a microprocessor and be protected from overload at all angles of rotation. Run time shall be constant, and independent of torque. A 2 to 10 VDC feedback signal shall be provided for position feedback or master-slave applications. If required, 1 SPDT auxiliary switch shall be provided having the capability of being adjustable. Actuators with auxiliary switch must be constructed to meet the requirements for Double Insulation so an electrical ground is not required to meet agency listings. Actuators shall be UL listed and CSA certified, have a 5 year warranty, and be manufactured under ISO 9001 International Quality Control Standards. Actuators shall be as manufactured by Belimo.

For Actuator Wiring Information and Diagrams, Please See Belimo Wiring Guide (pg 349).

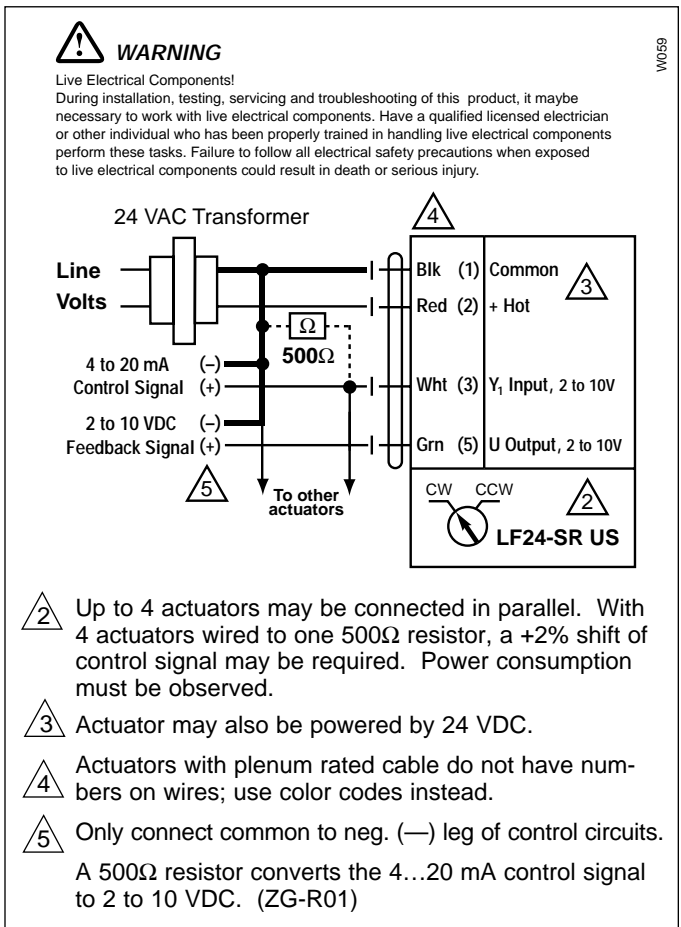

4 to 20 mA control of LF24-SR (-S) US with 2 to 10 VDC feedback output

Dimensions [All numbers in brackets are in millimeters.]

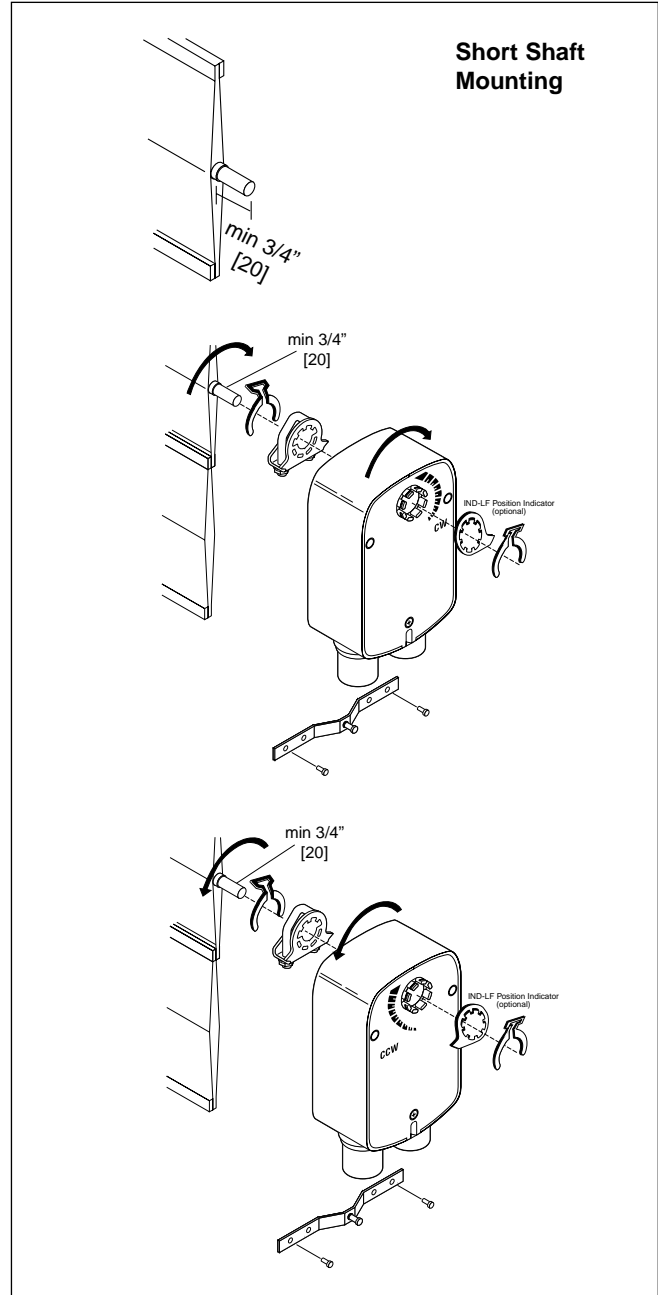
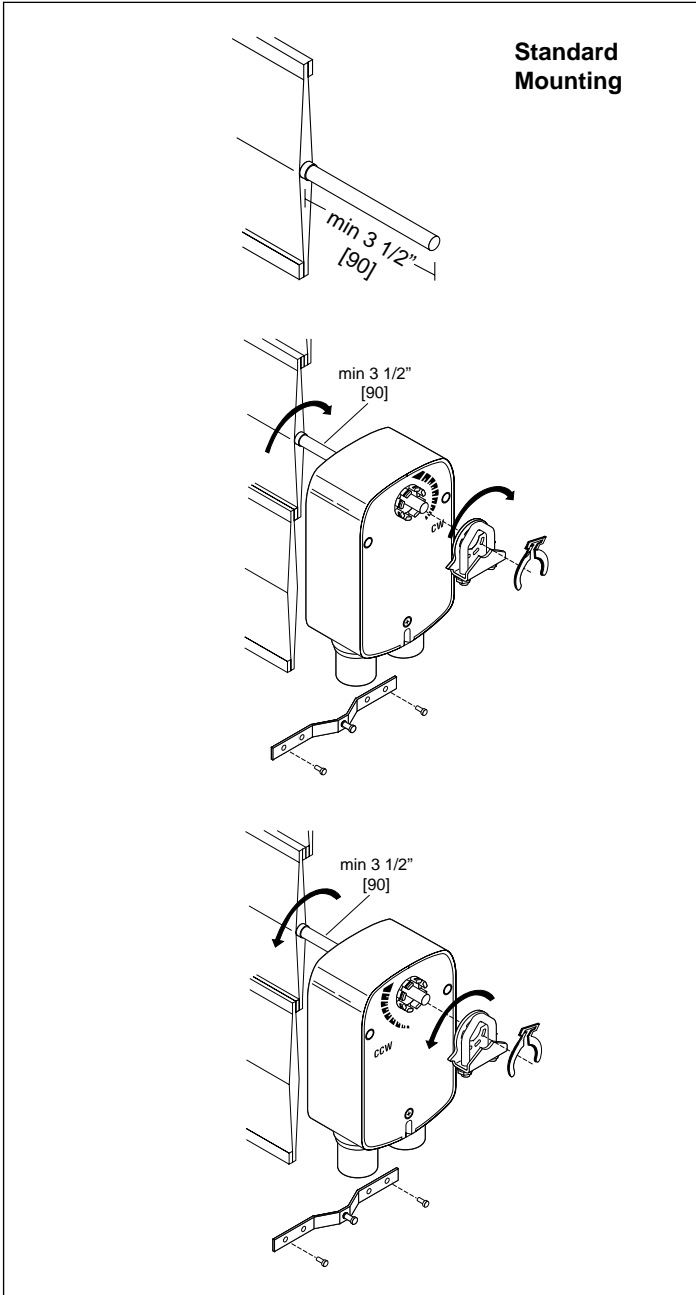

1. Rotate the damper to its failsafe position. If the shaft rotates counterclockwise, mount the "CCW" side of the actuator out. If it rotates clockwise, mount the actuator with the "CW" side out.
2. If the universal clamp is not on the correct side of the actuator, move it to the correct side.
3. Slide the actuator onto the shaft and tighten the nuts on the V-bolt with a 10mm wrench to 6-8 ft-lb of torque.
4. Slide the anti-rotation strap under the actuator so that it engages the slot at the base of the actuator. Secure the strap to the duct work with #8 self-tapping screws.

NOTE: Read the "Standard Mounting" instructions, on the next page, for more detailed information.

Preliminary steps

1. Belimo actuators should be mounted indoors in dry, relatively clean environment free from corrosive fumes. If the actuator is to be mounted outdoors, a protective enclosure must be used to shield the actuator. (See Belimo *Mechanical Accessories*)
2. For new construction work, **order dampers with extended shafts**. Instruct the installing contractor to allow space for mounting and service of the Belimo actuator on the shaft.
3. For standard mounting, the damper shaft must extend at least 3 1/2" from the duct. If the shaft extends less than 3 1/2", the actuator may be mounted in its short shaft configuration. If an obstruction blocks access, the shaft can be extended with the AV 10-18 shaft extension. (K6-1 is required)



Mechanical Operation

The actuator is mounted directly to a damper shaft up to 1/2" in diameter by means of its universal clamp, or up to a 3/4" shaft with the optional K6-1 clamp. A crank arm and several mounting brackets are available for applications where the actuator cannot be direct coupled to the damper shaft.

The LF series actuators provide true spring return operation for reliable fail-safe application and positive close-off on air tight dampers. The spring return system provides consistent torque to the damper with, and without, power applied to the actuator.

The LF series provides 95° of rotation and is provided with a graduated position indicator showing 0 to 95°.

The LF...-S versions are provided with 1 built-in auxiliary switch. This SPDT switch is provided for safety interfacing or signaling, for example, for fan start-up. The switching function is adjustable between 0° and 95°.

Standard Mounting / Airtight Damper Procedure

1. See Fig. B. Manually move the damper to the fail-safe position (a) (usually closed). If the shaft rotated counter-clockwise (↺), this is a CCW installation. If the shaft rotated clockwise (↻), this is a CW installation. In a Left Hand installation, the actuator side marked "CW" faces out, while in a CW installation, the side marked "CCW" faces out. All other steps are identical.
2. The actuator is usually shipped with the universal clamp mounted to the "CW" side of the actuator. To test for adequate shaft length, slide the actuator over the shaft with the side marked "CW" (or the "CCW" side if this is the side with the clamp). If the shaft extends at least 1/8" through the clamp, mount the actuator as follows. If not, go to the *Short Shaft Installation* section.
3. If the clamp is not on the correct side as determined in step #1, re-mount the clamp as follows. If it is on the correct side, proceed to step #5. Look at the universal clamp. If you are mounting the actuator with the "CCW" side out, position the clamp so that the pointer section of the tab is pointing to 0° (see Fig. C) and the spline pattern of the clamp mates with spline of the actuator. Slip the clamp over the spline. (Use the same procedure if the "CW" side is out.)
4. Lock the clamp to the actuator using the retaining clip.
5. Verify that the damper is still in its full fail-safe position. (a)
6. Mount the spring return actuator to the shaft. Tighten the universal clamp, finger tight only.
7. Mount the anti-rotation strap at the base of the actuator. Do not tighten the screws.
8. Remove the screw from one end of the mounting bracket and pivot it away from the actuator.
9. Loosen the universal clamp and, making sure not to move the damper shaft, rotate the actuator approximately 5° in the direction which would open the damper.
10. Tighten the universal clamp to the shaft.
11. Rotate the actuator to apply pressure to the damper seals (b) and re-engage the anti-rotation strap (c).
12. Tighten all fasteners.

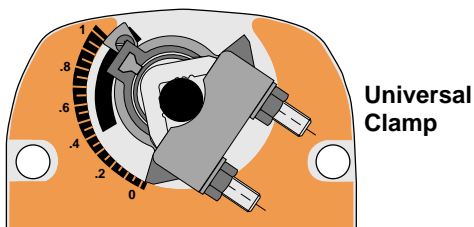
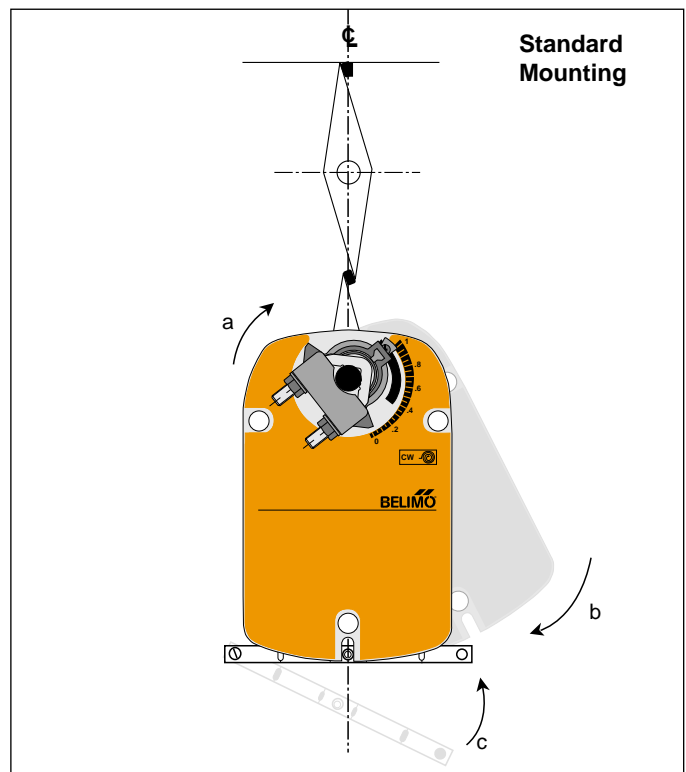
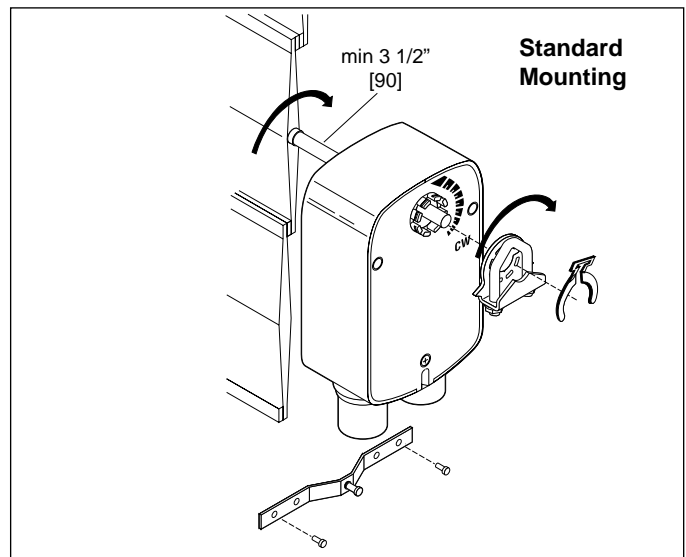

Fig. C

Fig. B

Short Shaft Mounting with IND-LF Position Indicator / Airtight Damper Procedure

If the shaft extends at least 3/4" from the duct, follow these steps:

1. (See Fig. D) Move damper blades to the fail-safe position (a).
2. Determine the best orientation for the universal clamp on the back of the actuator. The best location would be where you have the easiest access to the V bolt nuts on the clamp.
3. Engage the clamp to the actuator as close as possible to the determined location.
4. Lock the clamp to the actuator using the retainer clip.
5. Mount the spring return actuator to the shaft. Tighten the universal clamp, finger tight only.
6. Mount the anti-rotation strap at the base of the actuator. Do not tighten the screws.
7. Remove the screw from one end of the mounting bracket and pivot it away from the actuator.

8. Loosen the universal clamp and, making sure not to move the damper shaft, rotate the actuator approximately 5° in the direction which would open the damper.
9. Verify that the damper is still in its full fail-safe position.
10. Tighten the universal clamp to the shaft.
11. Rotate the actuator to apply pressure to the damper seals (b) and re-engage the anti-rotation strap (c).
12. Tighten all fasteners.
13. Use IND-LF accessory if position indication is needed.

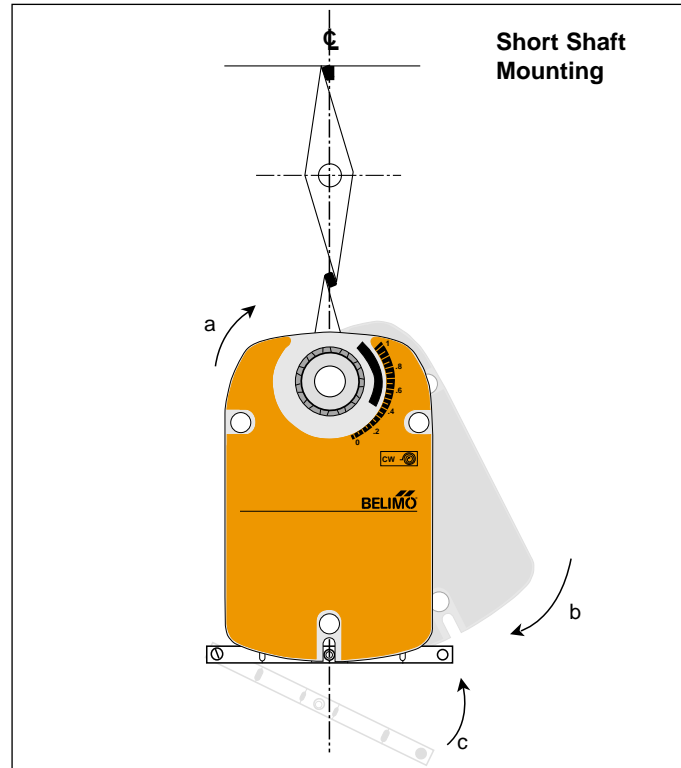
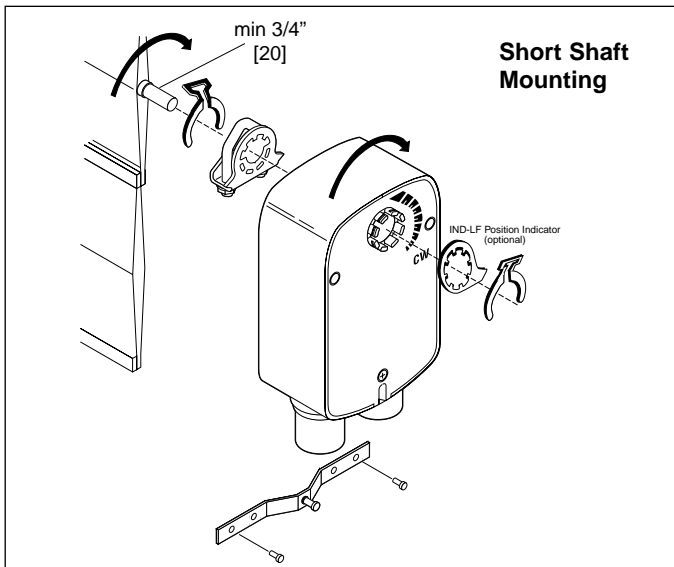

Fig. D

Operational Information for LF24-SR US and LF24-MFT... US Actuators

Initialization of the LF24-SR US and LF24-MFT... US

When power is applied, the internal microprocessor recognizes that the actuator is at its full fail-safe position and uses this position as the base for all of its position calculations. This procedure takes approximately 15 seconds. During this time you will see no response at the actuator. The microprocessor will retain the initialized zero during short power failures of up to 25 seconds. When power is applied during this period, the actuator will return to normal operation and proceed to the position corresponding to the input signal provided. For power failures over 25 seconds, the actuator will be at its fail-safe position and will go through the start up initialization again.

Motor position detection

Belimo brushless DC motors eliminate the need for potentiometers for positioning. Inside the motor are three "Hall Effect" sensors. These sensors detect the spinning rotor and send pulses to the microprocessor which counts the

pulses and calculates the position to within 1/3 of a revolution of the motor.

Overload protection

The LF, on-off actuators are electronically protected against overload. The LF, On-off actuators have an internal current limiter which maintains the current at a safe level which will not damage the actuator while providing adequate holding torque.

The LF24, modulating actuators (LF24-SR US, LF24-3 US, LF24-MFT US) are protected against overload by digital technology located in the ASIC. The ASIC circuitry constantly monitors the rotation of the brushless DC motor inside the actuator and stops the pulsing to the motor when it senses a stall condition. The motor remains energized and produces full rated torque during stall conditions. The actuator will try to move in the direction of the stall every 2 minutes, for a period of 32 minutes. After this, the actuator will try again every 2 hours.

Mechanical Angle of Rotation Limiting

The LF actuators are provided with an adjustable stop to limit the rotation of the actuator. This function works in conjunction with the universal clamp or the optional position indicator. The adjustable stop is needed when rotation of less than 95° is required. The LF actuator can be indefinitely stalled, in any position, without harming the actuator.

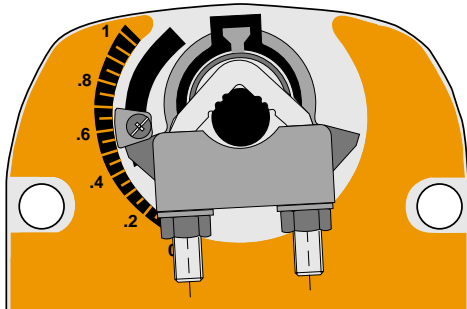

Using the universal clamp:

1. Loosen the end stop fastening screw using a #2 Phillips screwdriver.
2. Move the stop block so the bottom edge of the block lines up with the number corresponding to the desired degrees of rotation. (example: 45 degrees of rotation = .5)
3. Lock the block in place with the fastening screw.
4. Check the actuator for proper rotation.

Using the IND-LF position indicator with adjustable stop:

- Note: preferred method if short shaft mounting is used.
1. With the actuator in its fail-safe position, place the IND-LF Position Indicator so that it points to the 0 degree position.
 2. Loosen the end stop fastening screw using a #2 Phillips screwdriver.
 3. Move the stop block so the bottom edge of the block lines up with the number corresponding to the desired degrees of rotation. (example: 45 degrees of rotation = .5)
 4. Lock the block in place with the fastening screw.
 5. Check the actuator for proper rotation.

Direction of Rotation Switch

LF24-3 (-S) US and LF24-SR (-S) US actuators have a direction of rotation switch on the cover labeled "CW-CCW". Switch position indicates start point. For the LF24-SR, with the switch in position "CW", the actuator rotates clockwise with a decrease in voltage or current. With the switch in position "CCW", the actuator rotates counterclockwise with a decrease in voltage or current.

The LF24-3 (-S) US and LF24-SR (-S) US actuators rotate clockwise when the switch is in the "CW" position and power is applied to wire #3. When power is applied to wire #4 the actuator rotates counter clockwise.

Rotating the direction of rotation switch to "CCW" reverses the control logic.

*During checkout, the switch position can be temporarily reversed and the actuator will reverse its direction. This allows the technician a fast and easy way to check the actuator operation without having to switch wires or change settings on the controller. **When the check-out is complete, make sure the switch is placed back to its original position.***

Control Accuracy and Stability

LF24-SR US actuators have built-in brushless DC motors which provide better accuracy and longer service life.

The LF24-SR US actuators are designed with a unique non-symmetrical deadband. The actuator follows an increasing or decreasing control signal with a 80 mV resolution. If the signal changes in the opposite direction, the actuator will not respond until the control signal changes by 200 mV. This allows these actuators to track even the slightest deviation very accurately, yet allowing the actuator to "wait" for a much larger change in control signal due to control signal instability.

LF Actuator responds to a 80 mV signal when not changing direction from stop position.

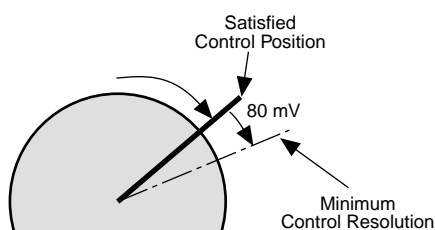

LF Actuator responds to a 200 mV signal when reversing direction from stop position.

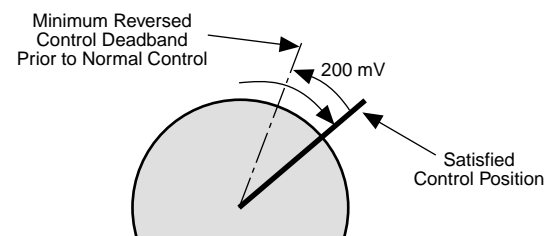

The LF24-MFT(-S) US control accuracy and stability can be found in the MFT specifications, page 293.

Auxiliary Switches

The ...-S model actuators are equipped with an adjustable auxiliary switch used to indicate damper position or to interface additional controls or equipment. Switching positions can be set over the full 0 to 95° rotation simply by setting a switch on the actuator.

1. Set desired switch position. (Example 60%)
2. As the actuator rotates, the switch indicator moves from .6 (60%) toward 0 (0%). When the indicator passes 0 the switch contact between S1 and S2 is broken and the contact between S1 and S3 is made.

Switch Rating

Voltage	Resistive load	Inductive load
120 VAC	3 A	1.03 A
250 VAC	3 A	0.5 A

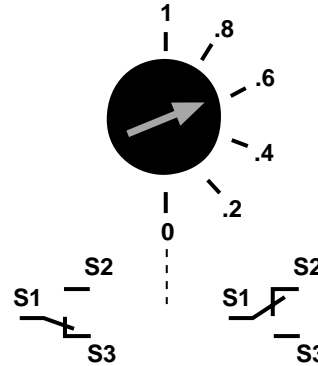

Non-direct Mounting Methods



KH-LF
For shafts up to 1/2"

KH-LF crankarm including retaining ring.

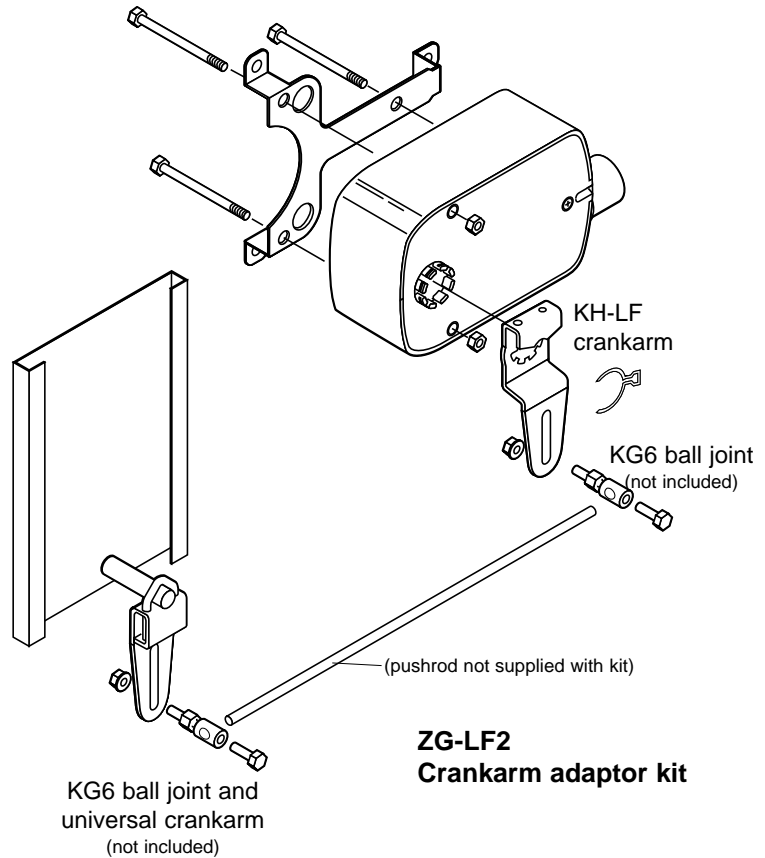

ZG-LF2
Crankarm adaptor kit

KG6 ball joint and
universal crankarm
(not included)

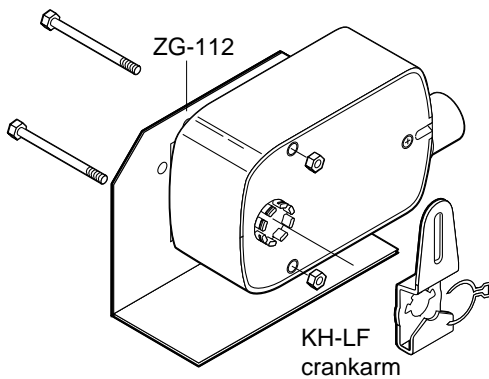

ZG-LF112
Crankarm adaptor kit

KH-LF
crankarm

WARNING The wiring technician must be trained and experienced with electronic circuits. Disconnect power supply before attempting any wiring connections or changes. Make all connections in accordance with wiring diagrams and follow all applicable local and national codes. Provide disconnect and overload protection as required. Use copper, twisted pair, conductors only. If using electrical conduit, the attachment to the actuator must be made with flexible conduit.

Always read the controller manufacturer's installation literature carefully before making any connections. Follow all instructions in this literature. If you have any questions, contact the controller manufacturer and/or Belimo.

Transformer(s)

The LF24... actuator requires a 24 VAC class 2 transformer and draws a maximum of 7 VA per actuator. The actuator enclosure cannot be opened in the field, there are no parts or components to be replaced or repaired.

- EMC directive: 89/336/EEC
- Software class A: Mode of operation type 1
- Low voltage directive: 73/23/EEC

CAUTION: It is good practice to power electronic or digital controllers from a separate power transformer than that used for actuators or other end devices. The power supply design in our actuators and other end devices use half wave rectification. Some controllers use full wave rectification. When these two different types of power supplies are connected to the same power transformer and the DC commons are connected together, a short circuit is created across one of the diodes in the full wave power supply, damaging the controller. Only use a single power transformer to power the controller and actuator if you know the controller power supply uses half wave rectification.

Multiple Actuators, One Transformer

Multiple actuators may be powered from one transformer provided the following rules are followed:

1. The TOTAL current draw of the actuators (VA rating) is less than or equal to the rating of the transformer.
2. Polarity on the secondary of the transformer is strictly followed. *This means that all No. 1 wires from all actuators are connected to the common leg on the transformer and all No 2 wires from all actuators are connected to the hot-leg. Mixing wire No. 1 & 2 on one leg of the transformer will result in erratic operation or failure of the actuator and/or controls.*

Multiple Actuators, Multiple Transformers

Multiple actuators positioned by the same control signal may be powered from multiple transformers provided the following rules are followed:

1. The transformers are properly sized.
2. All No. 1 wires from all actuators are tied together and tied to the negative leg of the control signal. See wiring diagram.

Wire Length for LF... Actuators

Keep power wire runs below the lengths listed in the table in Fig. A. If more than one actuator is powered from the same wire run, divide the allowable wire length by the number of actuators to determine the maximum run to any single actuator.

Example for LF24-SR us:

$$3 \text{ actuators, } 16 \text{ Ga wire} \\ 550 \text{ Ft} \div 3 \text{ Actuators} = 183 \text{ Ft. Maximum wire run}$$

Maximum Wire Length:

LF24 (-S) US

Wire Size	Max. Feet.		Wire Size	Max. Feet
12 Ga	1100 Ft.		18 Ga	260 Ft.
14 Ga	700 Ft.		20 Ga	140 Ft.
16 Ga	440 Ft.		22 Ga	75 Ft.

LF120 (-S) US / LF230 (-S) US

Wire Size	Max. Feet.		Wire Size	Max. Feet
12 Ga	1250 Ft.		18 Ga	320 Ft.
14 Ga	800 Ft.		20 Ga	160 Ft.
16 Ga	500 Ft.		22 Ga	85 Ft.

LF24-SR (-S) US / LF24-3 (-S) US / LFC24-3-R (-S) US / LF24-MFT... US

Wire Size	Max. Feet.		Wire Size	Max. Feet
12 Ga	1500 Ft.		18 Ga	375 Ft.
14 Ga	925 Ft.		20 Ga	200 Ft.
16 Ga	550 Ft.		22 Ga	100 Ft.

Fig. A

Wire Type and Wire Installation Tips

For most installations, 18 or 16 Ga. cable works well with the LF24... actuators. Use code-approved wire nuts, terminal strips or solderless connectors where wires are joined. It is good practice to run control wires unspliced from the actuator to the controller. If splices are unavoidable, make sure the splice can be reached for possible maintenance. Tape and/or wire-tie the splice to reduce the possibility of the splice being inadvertently pulled apart.

The LF24... proportional actuators have a digital circuit that is designed to ignore most unwanted input signals (pickup). In some situations the pickup may be severe enough to cause erratic running of the actuator. For example, a large inductive load (high voltage AC wires, motors, etc.) running near the power or control wiring may cause excessive pickup. To solve this problem, make one or more of the following changes:

1. Run the wire in metallic conduit.
2. Re-route the wiring away from the source of pickup.
3. Use shielded wire (Belden 8760 or equal). **Ground the shield to an earth ground. Do not connect it to the actuator common.**

Brushless DC Motor Operation

Belimo's brushless DC motor spins by reversing the poles of stationary electromagnets housed inside rotating permanent magnets. The electromagnetic poles are switched by a micro-processor and a special ASIC (Application Specific Integrated Circuit) developed by Belimo. Unlike the conventional DC motor, there are no brushes to wear or commutators to foul.

Startup and Checkout



Instructions For LF24-SR (-S) US and LF24-MFT...US + P100

LF24-SR (-S) US and LF24-MFT...US + P100 Electrical check-out procedure

Step	Procedure	Expected Response	Gives Expected Response Go To Step...	Does Not Give Expected Response Go To Step...
1.	Remove power to reset actuator. Re-apply power. Apply control signal to actuator.	Actuator will move to its "Control Signal" position.	Actuator operates properly Step 8.	No response at all Step 2. Operation is reversed Step 3. Does not drive toward "Control Signal Position" Step 4.
2.	Check power wiring. Correct any problems. See Note 1.	Power supply rating should be \geq the total power requirement of the actuator(s). Minimum voltage of 19.2 VAC or 21.6 VDC.	Power wiring corrected, actuator begins to drive Step 1.	Power wiring corrected, actuator still does not drive Step 4.
3.	Turn reversing switch to the correct position. Make sure the switch is turned all the way left or right.	Actuator will move to its "Control Signal" position.	Actuator operates properly. Step 8.	Does not drive toward "Control Signal Position" Step 4.
4.	Make sure the control signal positive (+) is connected to Wire No 3 and control signal negative (-) is connected to wire No. 1. Most control problems are caused by reversing these two wires. Verify that the reversing switch is all the way CCW or CW.	Drives to "Control Signal" position	Actuator operates properly Step 8.	Step 5.
5.	Check input signal with a digital volt meter (DVM). Make sure the input is within the range of the actuator. For LF24-SR US this is 2 to 10 VDC or 4 to 20 mA. Note: The input signal must be above the 2 VDC or 4 mA to have the actuator move.	Input voltage or current should be $\pm 1\%$ of what controller's adjustment or programming indicate.	Controller output (actuator input) is correct. Input Polarity Correct Step 6.	Reprogram, adjust repair or replace controller as needed Step 1.
6.	Loosen the nuts on the V-bolt and move the damper by hand from fully closed to fully open.	Damper will go from fully closed to fully open.	Damper moves properly Step 7.	Find cause of damper jam and repair. Move damper back to the fully closed position and tighten the nuts Step 1.
7.	Check damper torque requirement.	Torque requirement is \leq actuator's minimum torque.	Defective Actuator. Replace Actuator - See Note 2.	Recalculate actuator requirement and correct installation.
8.	Actuator works properly. Test controller by following controller manufacturer's instructions.			

Note 1 Check that the transformer(s) are sized properly.

- If a common transformer is used, make sure that polarity is observed on the secondary. This means connect all No. 1 wires to one leg of the transformer and all No. 2 wires to the other leg of the transformer.
- If multiple transformers are used with one control signal, make sure all No. 1 wires are tied together and tied to control signal negative (-).
- Controllers and actuators must have separate 24 VAC/VDC power sources.

Note 2 If failure occurs within 5 years from original installation date, notify Belimo and give details of the application.