

# GPCED101-103 INSTALLATION AND OPERATION GUIDE

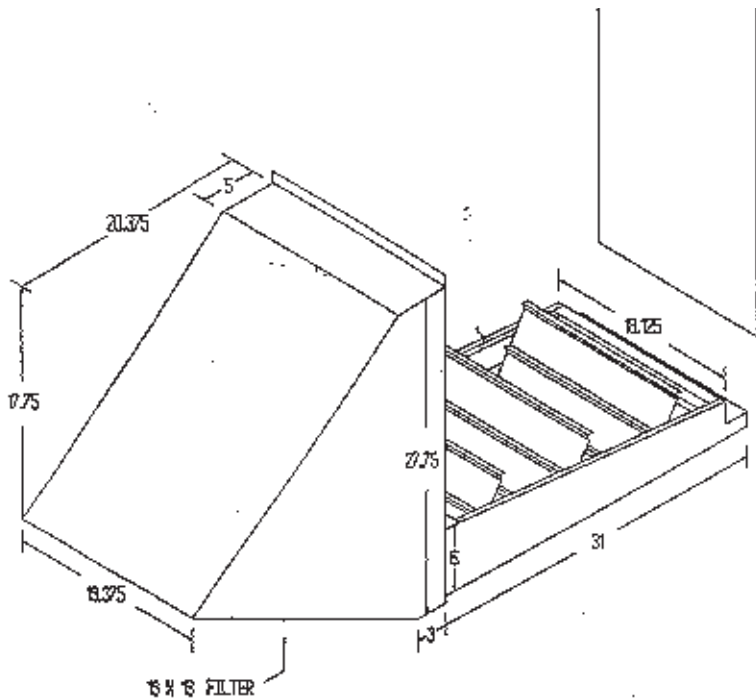

- to cool the space. (Go to step 5.)
4. Outdoor air dampers open to minimum position and the compressor engages to provide mechanical cooling.
  5. When the thermostat is satisfied the outside air dampers return to a closed position.

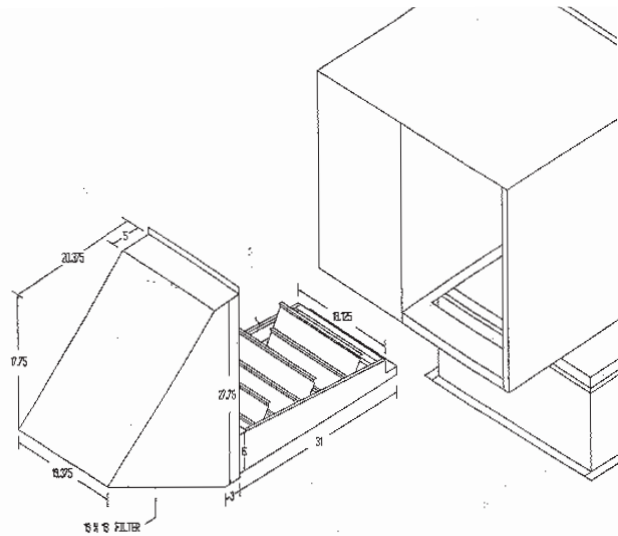

Figure 1

## ECONOMIZER 101

## INSTALLATION

Economizers are designed to provide “free” air conditioning when outside conditions are appropriate. When the outside air is cool and dry enough, the economizer automatically opens to introduce the cool air to the interior space, thereby eliminating the need to run the air conditioning compressor.

If the outside air becomes too warm or humid, the economizer automatically closes the fresh air damper and the compressor engages to begin cooling the space mechanically.

If a two stage thermostat is used it is possible to use a combination of economizer and mechanical cooling to condition the space.

The economizer can also be set to allow a minimum amount of fresh air to enter the space when the equipment’s indoor blower is operating.

Economizers are valuable tools to enhance indoor air quality, save energy and prolong the life of the air conditioning equipment.

## SEQUENCE OF OPERATION

This sequence assumes employment of a single enthalpy economizer using a two stage thermostat.

1. A call for cooling comes from room thermostat.
2. The enthalpy sensor determines if the atmospheric conditions are conducive for using outside air for cooling. If YES, go to step 3. If NO, or if outdoor air temperature rises above enthalpy set point, go to step 4.
3. The outside air dampers open and modulate to maintain a mixed air temperature (outside air + indoor air) of 53 degrees F. If the outdoor air is insufficient to satisfy the thermostat alone and a second stage of cooling is required, the compressor starts and works in conjunction with the economizer

**NOTE: THIS ACCESSORY REQUIRES THE PCCP101-103 AND PCP101-103 ROOF CURB AND PLENUM ACCESSORIES.**

1. Open carton and inspect contents for shortages and damage.
2. Disconnect the power to the unit.
3. Remove large blower access panel from package unit.
4. Remove the panel from the return air side of the PCP101-103.
5. Remove the filter door from the PCP101-103.
6. Slide the damper/hood assembly into the PCP101-103 opening until the return air dampers are above the downflow return air opening and the fresh air hood is against the side of the unit.
7. Attach the hood to the side of the unit using sheet metal screws.

**NOTE:** Ensure that the wires do not interfere with either the fresh air or return air damper operation. The wires should not be pinched between the fresh air hood and the unit or the return air dampers and the base pan.

8. Hard wire to the unit per the attached wiring diagram.
9. Seal the PCP101-103 and the economizer until water tight.
10. Restore power to the unit
11. Determine the proper enthalpy setting using enclosed control documentation if it is different from the factory ‘D’ setting.
12. Determine the minimum position setting using the minimum set point equation on page two.
13. Replace the blower access panel and filter access panel.

## MINIMUM SET POINT EQUATION

## CONTENTS

$$(T_o \times OA) + (T_r \times RA) = T_m$$

**To = Outdoor air temperature**

**OA= Percent of outdoor air**

**Tr = Return air temperature**

**RA= Percent of return air**

**Tm= Resulting mixed air temperature**

### Example:

Fresh air required is 10% outdoor air.

Outdoor air temperature is 60 degrees F.

Return air temperature is 75 degrees F.

$$(0.1 \times 60) + (0.9 \times 75) =$$

$$6.0 + 67.5 = 73.5$$

Mixed air temperature will be 73.5 degrees F when the OA is 60 degrees F and the RA is 75 degrees F with 10% outdoor air.

1	Damper rack w/ economizer controls
1	Installation guide
1	Honeywell control literature

## ACCESSORIES / CAPABILITIES

Dual Enthalpy - Requires an additional C7400 enthalpy control installed in the return air duct.

Demand Control Ventilation - Requires a CO2 sensor.

Remote Minimum Positioner - For applications requiring minimum position adjustments inside the conditioned space.

## Important Notes

**Please see enclosed brochure for Honeywell component trouble shooting instructions.**

**Controller is factory set for power exhaust to engage when the dampers are 70% open.**

**A two stage thermostat is recommended with this accessory.**

**The fresh air requires a 19 X 19 X 2 hog hair filter.**

PCEC101-103  
WIRING DIAGRAM

JUMPER (OCCUPIED)

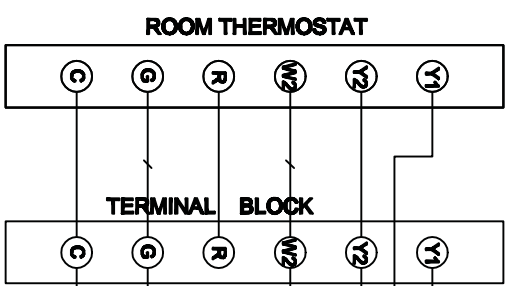
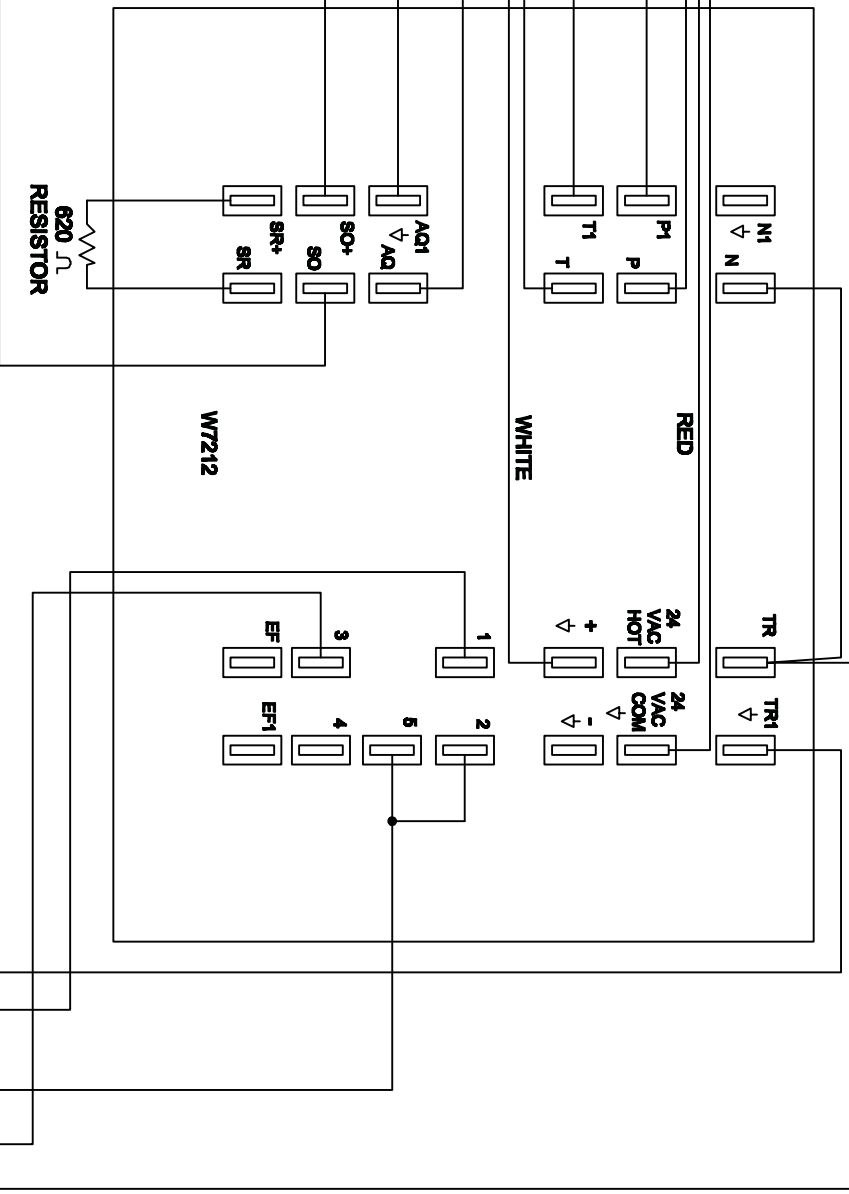
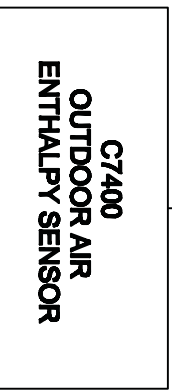
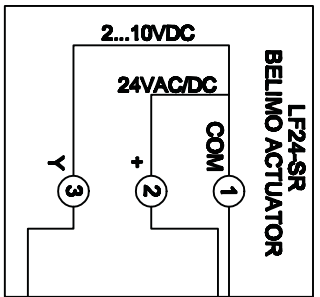

TERMINAL BLOCK

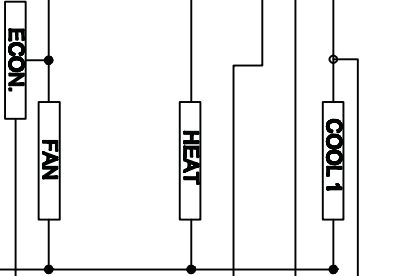

- COLOR CODES
- ① (P) PURPLE
  - ② (Y/R) YELLOW / RED
  - ③ (G) GREEN
  - ④ (BL) BLUE
  - ⑤ (Y) YELLOW

(M)  
(P)  
(Y/R)  
(BL)  
(G)