

# GPCEH101-103/GPHEH101-103

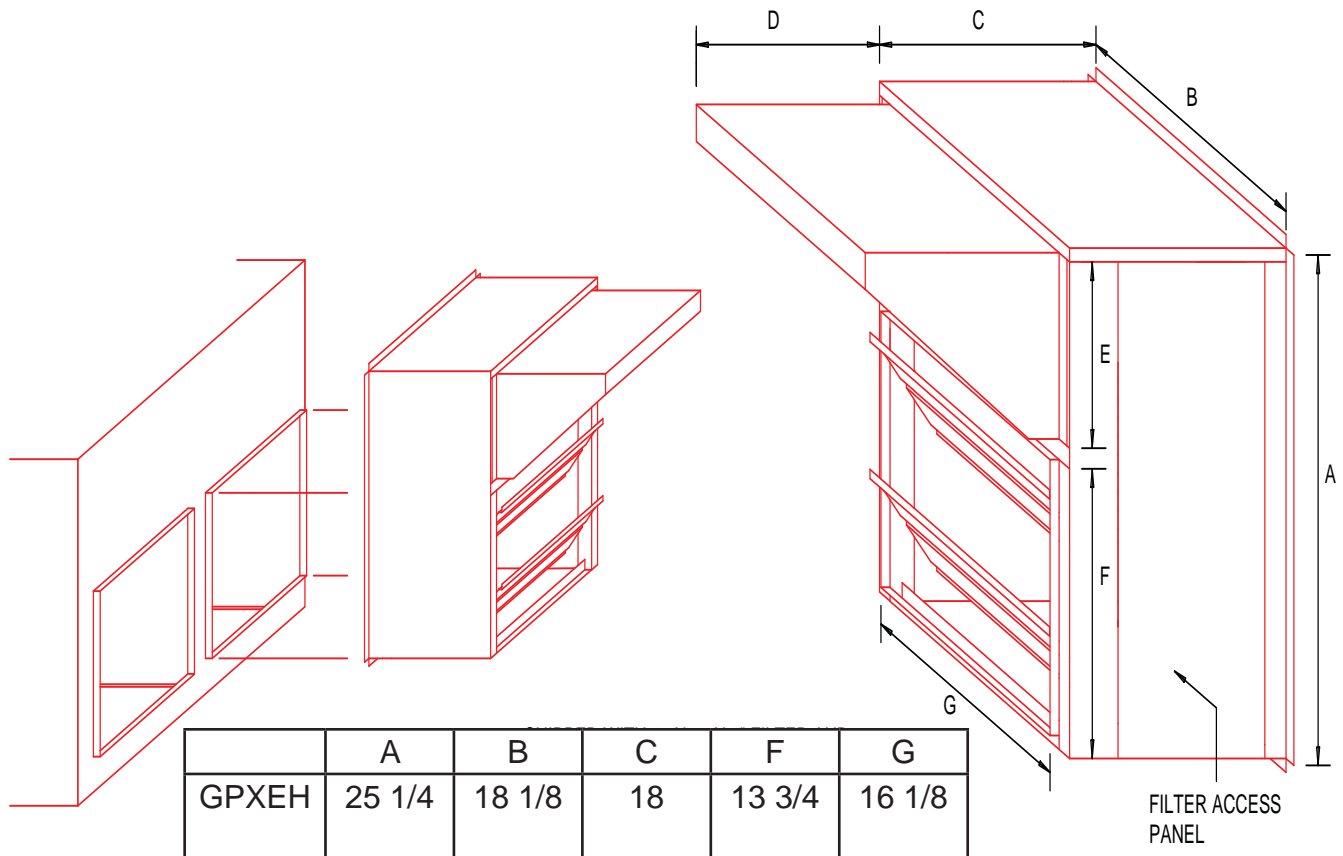

## SPECIFICATIONS

- FULLY MODULATING
- UP TO 100% FRESH AIR
- HONEYWELL ECONOMIZER CONTROL
- SINGLE ADJUSTABLE ENTHALPY CONTROL CONVERTIBLE TO DUAL ENTHALPY
- ADJUSTABLE MINIMUM FRESH AIR
- FACTORY WIRED
- ELECTRIC (GS) AND HEAT PUMP (HP) MODELS AVAILABLE
- FITS ALL MODELS 3 - 5 TONS